



KT557

Telehandler

Flexibility and efficiency in one

The Kramer telehandler KT557 offers the sturdiness of a wheel loader in combination with the advantages of a telehandler. Maximum 7 m stacking height and a 5.5 metric ton payload make it stand out. Interacting with the standard EcospeedPRO drive system, the strong Deutz engine ensures maximum performance efficiency. The comprehensive standard components, as well as a wide variety of options, make optimum adaptation possible in a large range of application areas.

Hydraulics: Load-sensing hydraulic pump with a discharge volume of max. 187 l/min for quick load cycles

Frame: Torsion-resistant frame in box profile design with lateral support for the telescopic arm

Operating concept: 7" LCD display, all-in-one joystick and jog dial control element for easy machine control

Efficiency: Powerful Deutz TCD 4.1 engine and ecospeedPRO gearbox with 40 km/h as standard and rpm reduction for efficient transportation work

EquipCare: The machine's figures and data at a glance with the telematic solution installed as standard

Technical Data

Standard engine data

Engine manufacturer	Deutz
Drive output	115 kW
Drive output	156 PS
at max. rpm	2,300 U/min
Cylinder capacity	4,038 cm ³
Exhaust standard level	V
Exhaust aftertreatment	DOC / DPF / SCR

Weights

Payload (max.)	5,500 kg
Payload at max. reach	2,000 kg
Payload at max. stacking height	4,000 kg
Stacking height (max.)	7,017 mm
Payload max. (LSP 500 mm)	5,500 kg
Operating weight	9,500 - 10,500 kg
Thrust force (max.)	67.6 kN

Lift capacity (max.) 56.7 kN

Filling levels

Tank capacity for hydraulic oil	100 l
Tank capacity for urea solution	12 l

Drive system

Travel speed Standard	0-40 km/h
Travel speed Option 1	0-20 km/h
Travel speed Option 2	0-30 km/h
Differential lock	100% self-locking differential connectable in the front axle

Steering

Steering angle max.	38 degree
---------------------	-----------

Noise characteristic values

Guaranteed sound power level LwA (cabin)	101 dB(A)
Measured sound power level LwA	97.1 dB(A)
Sound pressure level at the operator's ear	72 dB(A)

Dimensions

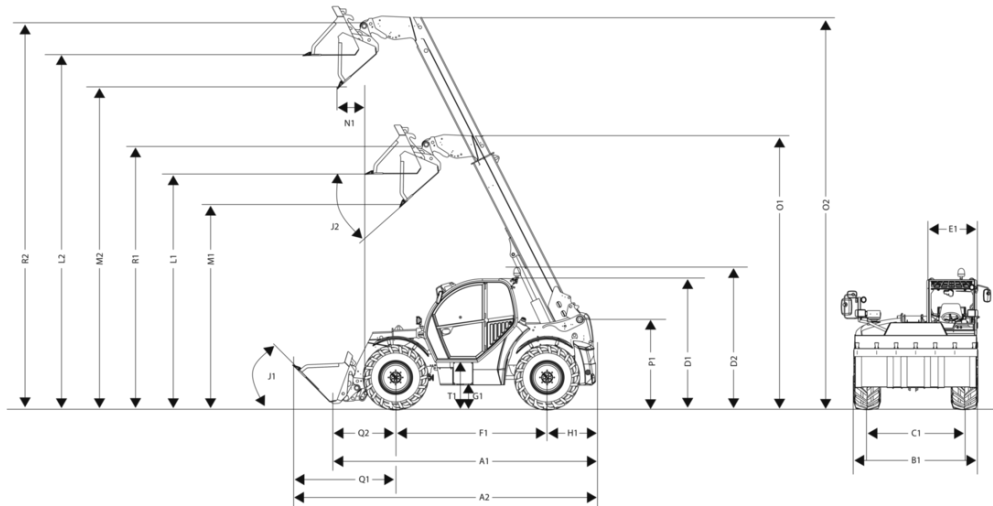

A1	Total length	4,985 mm
A2	Total length with bucket	6,160 mm
B1	Total width without bucket	2,500 mm
C1	Front track: rear	2,065 mm
E1	Cab width	990 mm
F1	Wheel base center	2,950 mm
G1	Ground clearance under axle and transmission, wading depth	418 mm
H1	Distance center rear wheel to rear	950 mm
I1	Rear approach angle (slope angle)	35 °
J1	Dumping angle	45 °
J2	Dumping angle	41 °
L1	Load-over height: retracted	4,518 mm
L2	Load-over height: extended	6,835 mm
M1	Dumping height: retracted	3,865 mm
M2	Dumping height: extended	6,183 mm
N1	Dumping width: extended	495 mm
O1	Tele extension length: retracted	5,287 mm
O2	Tele extension length: extended	7,604 mm
P1	Total height telescopic arm mounting in frame	1,761 mm
Q1	Distance center front wheel to bucket leading edge	2,260 mm
Q2	Distance center front wheel bearing quick change frame	935 mm
R1	Bucket pivot point: retracted	5,092 mm
R2	Bucket pivot point: extended	7,409 mm
S1	Turning radius outer edge wheels	4,240 mm
S2	Turning radius outer edge bucket	5,265 mm
T1	Entry height cab floor	975 mm
D1	Total height	2,570 mm
D2	Total height with rotating beacon	2,740 mm
K1	Max. stacking height	7,017 mm