



ET75

Tracked Conventional Excavator

durable and powerful

Constructed of high-grade steel and other quality, heavy-duty components for extreme durability. Other impressive features of the ET75 include high stability, increased lift capacity and an optional dozer blade. The large diesel tank allows for longer working times between refueling and ensures better performance.

Highlights

- Powerful drive system with LUDV
- Optimal maintenance access
- High degree of digging power
- AUX I
- Optimized hydraulics or engine-pump management

Technical Data

Hydraulic

Operating pressure hydraulics	285.0 bar
Flow rate	144.0 l/min
Tank capacity	96.0 l

Mechanical - Output Details

Nominal rotation speed	2,000.0 1/min
Travel speed stage 1	2.5 km/h
Travel speed stage 2	4.8 km/h

Mechanical Details

Length	6,270.0 mm
Width	2,252.0 mm
Height	2,559.0 mm
Operating weight	7,300.0 kg
Operating weight (min.-max.)	7,300.0 kg
Digging depth (max.)	4,097.0 mm

Engine

Cooling	Water-cooling
Engine type	Diesel engine
Cylinder capacity	3,054.0 cm ³
Inclined position max.	30.0 °
Tank capacity	145.0 l

Oil filling max.	145.0 l
Effective power	35.9 KW
Nominal Engine speed	2,000.0 1/min
Operating power	35.9 KW
Operating Engine speed	2,000.0 1/min
Exhaust-gas limit	中国四 (China IV)
Starter battery Voltage	12.0 V
Battery capacity (nom. value)	120.0 Ah
Engine Manufacturer	Yanmar
Engine Designation	4TNV94L-ZCWWN_35,9KW@2000

Environment Data

Sound power LWA, measured	99.0 dB(A)
Sound power LWA, guaranteed	99.0 dB(A)

Operating Fluids

Oil volume	11.600 l
Cooling fluid volume	10.0 l
Hydraulic fluid volume	105.0 l

Chassis

Traction drive	Axialpistonmotor with RGU
Operating pressure	285.0 bar

■ Shipping and Storage

Length for shipping	6,270.0 mm
Width for shipping	2,252.0 mm

Height for shipping	2,559.0 mm
Shipping weight	7,115.0 kg

Available engines

■ Yanmar

Cooling	Water-cooling
Engine type	Diesel engine
Cylinder	4
Cylinder capacity	3,054 cm ³
Fuel	Diesel EN 590
Effective power	35.9 KW
Nominal Engine speed	2,000 1/min
Idling speed	1,000 1/min
Engine speed (max. torque)	1,400 1/min
Engine Manufacturer	Yanmar
Stroke	110 mlai
Bore	94 mlai

Dimensions

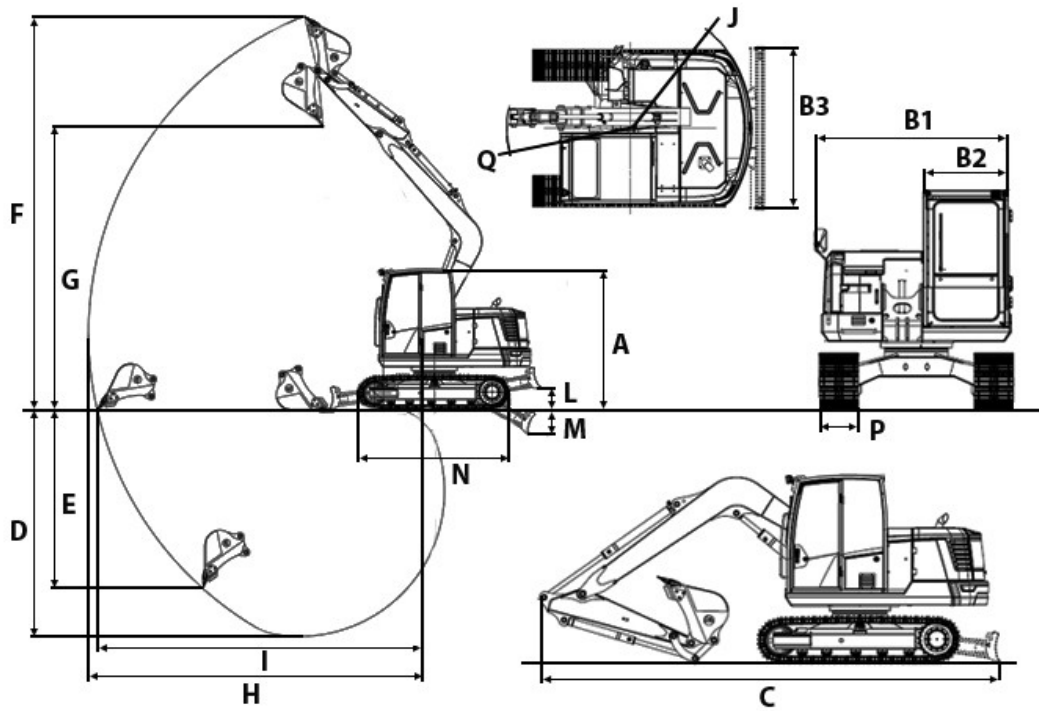

A	Height with cab	2,559 mm
B1	Width of upper carriage	2,252 mm
B2	Width of cab	988 mm
B3	Width of dozer blade	2,320 mm
C	Transport length	6,270 mm
D	Digging depth max.	4,097 mm
E	Piercing depth max.	3,219 mm
F	Piercing height max.	7,139 mm
G	Dumping height max.	5,153 mm
H	Digging radius max.	6,264 mm
I	Max. reach at ground level	6,106 mm
J	Tail swing radius	1,777 mm
L	Stacking height max. (dozer blade above surface)	390 mm
M	Digging depth max. (dozer blade below surface)	452 mm
N	Length travel drive	2,755 mm
P	Track width	450 mm
Q	Boom swing radius center	1,753 mm