



2060 Wheel loaders

Technical Data

■ Standard engine data

Engine manufacturer	Rehiko
Motor type	KDI 1903 TCR
Cylinder	3
Drive output	42 kW
Drive output	57 PS
at max. rpm	2,600 U/min
Maximum torque	225 Nm
Cylinder capacity	1,861 cm ³
Type of coolant	Water
Exhaust standard level	V
Exhaust aftertreatment	DOC/DPF

■ Electrical system

Operating voltage	12 V
Battery	100 Ah
Alternator	120 A

■ Weights

Operating weight	3,720 - 4,230 kg
Thrust force (max.)	4,320 daN
Lift capacity (max.)	3,925 daN
Tipping load with bucket – machine straight, loading frame horizontal	2,910 - 3,510 kg
Tipping load with bucket – machine pivoted, loading frame horizontal	2,550 - 3,070 kg
Tipping load with bucket - machine straight, loading frame in lowest position	4,400 - 5,280 kg
Tipping load with bucket - machine pivoted, loading frame in lowest position	3,860 - 4,630 kg
Tipping load with pallet fork – machine straight, loading frame horizontal	2,410 - 2,890 kg
Tipping load with pallet fork – machine pivoted, loading frame horizontal	2,110 - 2,530 kg
Tipping load with pallet fork - machine straight, transport position	2,870 - 3,440 kg
Tipping load with pallet fork - machine pivoted, transport position	2,520 - 3,020 kg

■ Driver's cab

Driver's cab	FSD (cabin)
--------------	-------------

■ Filling levels

Tank capacity for fuel	80 l
Tank capacity for hydraulic oil	32 l

■ Drive system

Type of drive	ecDrive (Electronic Controlled Drive)
drive unit	hydrostatic via transfer gearbox and universal joint shaft
Speed levels	2
Axle	PA 1200
Travel speed Standard	0-20 km/h
Travel speed Option 1	0-30 km/h
Operating brake	Drum brake (option: multi-disc brakes)
Parking brake	Drum brake (option: multi-disc brakes)
Differential lock	100 % front axle + rear axle

■ Hydraulic system

Drive hydraulics working pressure (max.)	500 bar
Work hydraulics discharge volume (max.)	59 (74,1) l/min
Work hydraulics working pressure (max.)	235 bar

■ Kinematics

Kinematics type	PZ
Lifting cylinder	2
Tipping cylinder	1
Quick change system	hydraulic

■ Steering

Steering type	hydraulically activated articulated pendulum steering
Steering cylinder	1
Oscillating angle	± 10 degree

■ Noise characteristic values

Average sound power level LwA (operator's canopy)	99.9 dB(A)
---	------------

Guaranteed sound power level LwA (operator's canopy) 101 dB(A)

Specified sound pressure level LpA (operator's canopy) 70 dB(A)

Average sound power level LwA (cabin) 99.9 dB(A)

Guaranteed sound power level LwA (cabin) 101 dB(A)

Specified sound pressure level LpA (cabin) 69 dB(A)

■ **Other information**

FSD = operator's canopy

DPF = diesel particulate filter

DOC = diesel oxidation catalyst

SCR = selective catalytic reduction

Tipping load calculation pursuant to ISO 14397

Dimensions

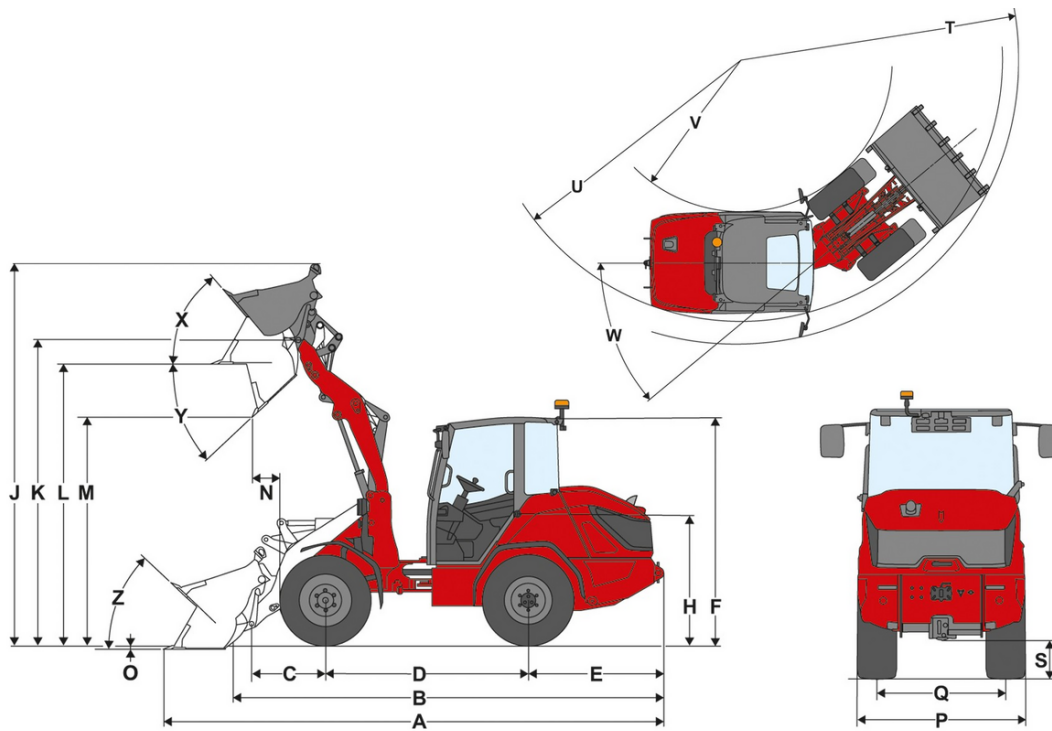

	Standard components	365 / 70 R 18 BKT MP513 ET20
A	Total length	5,295 mm
B	Total length without bucket	4,480 mm
C	Bucket pivot point (to center of axle)	785 mm
D	Wheel base	2,150 mm
E	Rear overhang	1,435 mm
F	Height with lowered operator's canopy	2,345 mm
	Height with operator's canopy raised	2,425 mm
	Height with cab	2,425 mm
H	Seat height	1,400 mm
J	Total working height	4,065 mm
K	Bucket pivot point (max. lift height)	3,240 mm
L	Load-over height	2,950 mm
M	Dumping height	2,415 mm
N	Reach (at M)	290 mm
O	Digging depth	35 mm
P	Total width	1,520 mm
Q	Track width	1,160 mm
S	Ground clearance	345 mm
T	Maximum external radius	4,125 mm
U	Radius on the outer edge	3,850 mm
V	Inner radius	2,225 mm
W	Articulation angle	40 °
X	Rollback angle at max. lift height	50 °
Y	Dumping angle	44 °
Z	Rollback angle on ground	43 °

Standard components

Engine

- Rehlko KDI 1903 TCR, {42.0 kW / 57.1 PS}{42.0 kW / 56.3 hp} (DOC/DPF), EU: Stage V

Steering system

- Hydraulically activated articulated pendulum steering
- Steering cylinder: 1

Operator's cab

- Operator's canopy ROPS / FOPS tested, rear windshield
- Generous provision of space
- Mirror on the left and right
- Ergonomic, generous access
- Adjustable steering wheel (incline and height)
- Right armrest

Operator's seat

- Synthetic leather seat with safety belt, fully sprung, weight, backrest and length adjustment

Lighting

- Lighting according to StVZO
- LED Basic worklights (1000 lm) on the roof, 2 at the front, 1 at the rear

Drive system & Axles

- Axle: planetary axle PA1200
- Drive: Hydrostatic all-wheel drive, electronically controlled, ecDrive (Electronic Controlled Drive)
- operating modes: Auto Mode; ECO Mode (reduction of engine speed when set speed is reached)
- Lock: 100%, electrically-hydraulically switchable on front and rear axles
- Speed: {20 km/h (optional 30 km/h)}{12.4 mph (optional 18.6 mph)}
- Travel speeds: 2 | {10 km/h / 20 km/h}{6.2 mph / 12.4 mph}
- Operating brake: drum brake on the front axle acting on the rear axle via the universal joint shaft
- Parking brake: drum brake - actuation via the handbrake lever on the front axle acting on the rear axle via the universal joint shaft

Tires

- 365/70 R 18 BKT Multimax MP 513 ET20, tread pattern AS, width {1520 mm}{59.84 in}, height {2425 mm}{95.47 in}

Loading system

- Load arm LS937
- Quickhitch facility (Weidemann HV/HT - C) hydraulic
- Kinematics: PZ
- Lifting cylinder: 2
- Tipping cylinder: 1
- Floating position for lifting cylinder

Hydraulics

- Electrically pilot-controlled joystick with direction switch and integrated button for differential lock
- 3. Front control circuit electrically proportional via joystick, incl. continuous function
- Working hydraulics {59 l/min (22,9 ccm)}{15.6 gpm (1.4 in³)}
- Hydraulic oil cooler

EquipCare (telematics)

- EquipCare 36 months

Options

Operator's cab

- Low driver's canopy, including rear window
- 1-door cab, including heating and ventilation
- Two-piece cab door
- Front and rear windows, including front and rear windshield wipers
- Air conditioning
- DAB+ radio preparation (antenna, speakers)

The illustrations, equipment and data shown may deviate from the current delivery program of your country. Optional equipment subject to additional charge may be shown. Subject to changes.

- DAB+ radio complete
- 1 power outlet: 2xUSB
- Sun blind
- Storage box (left of driver's seat)
- Panoramic mirror inside

Operator's seat

- Fabric seat; MSG85
- Artificial leather seat; air-sprung; MSG95
- Fabric seat; air-sprung; high backrest; MSG95
- Fabric seat; air-sprung; heated seat; MSG95
- Fabric seat; air-sprung; heated seat; high backrest; MSG95
- Fabric seat; air-sprung; MSG95
- Fabric seat; high backrest; MSG85

Lighting

- LED lighting according to StVZO
- LED Performance worklights (2000 lm) on the roof, 2 at the front, 2 at the rear
- Rotating beacon LED (yellow), (The national regulations must be observed.)

Approval & Road traffic

- Individual operating permit < {25 km/h}{15.5 mph}
- Individual operating permit > {25 km/h}{15.5 mph}
- Front and rear license plate bracket
- Warning triangle (the national requirements must be observed.)

Drive system & Axles

- Manual throttle
- Pre-heating: Coolant, hydraulic oil; 230 V, plug receptacle type E/F
- Pre-heating: Coolant, hydraulic oil; 230 V, plug receptacle type J
- Pre-heating: Coolant, hydraulic oil; 230 V, plug receptacle type G
- Driving mode Auto / Eco / Attachments
- Driving mode Auto / Eco / M-Drive
- Speed limiter proportional (slow speed device)
- {20 km/h}{12.4 mph} speed increase
- {30 km/h}{18.6 mph} speed increase
- Electro-hydraulic multi-disc brakes with spring suspension in the front axle acting on rear axle via universal joint shaft, incl. hill-hold function

Tires

- 425/55 R 17 Alliance 570 ET-15, profile AS, width {1655 mm}{65.16 in}, height {2386 mm}{93.94 in}
- 440 / 50 R 17 BKT Trac Super ET-15, RP profile, width {1671 mm}{65.79 in}, height {2377 mm}{93.58 in}
- 340 / 80 R 18 Alliance 585 ET15, profile MPT, width {1515 mm}{59.65 in}, height {2441 mm}{96.1 in}
- 405 / 70 R 18 Alliance 608 ETO, profile MPT, width {1608 mm}{63.31 in}, height {2453 mm}{96.58 in}

Loading system

Quickhitch plates:

- SkidSteer (hydraulic - SAEJ2513 SSL HV)
- Euro (hydraulic - ISO23206 EURO HV) (incl. two couplings SVK size 3)
- Euro (hydraulic - ISO23206 EURO HV) + SMS HV (incl. two couplings SVK size 3)
- Weidemann HV/HT - C - ECS (hydraulic - easy coupler system)

Other:

- Lowering brake valve (hose burst valves for lift and tipping cylinders)
- Load arm dampening
- Bucket status display

Bio-hydraulic oil

- Shell PANOLIN S4 HLP Synth 46 (bio hydraulic oil)

Hydraulics in front

- Working hydraulics {74.1 l/min (28.5 ccm)}{19.6 gpm (1.74 in³)}
- Pressureless return at front (1 x flat face size 3, plug) incl. leak oil line (1 x flat face size 2, plug)
- Faster quick coupling, double - machine side + attachment side
- Pressure relief 3rd control circuit at the front of the loading system

Hydraulics in rear

- Rear single-acting hydraulic connection via changeover valve (two SVK size 3 couplings)

The illustrations, equipment and data shown may deviate from the current delivery program of your country. Optional equipment subject to additional charge may be shown. Subject to changes.

Electrical connections in front

- Front plug receptacle, 13-pole (2x electric functions E1/ E2 and lighting); Operation: Via 2 buttons on the joystick; 1st pressing function, 2nd latching function
- Front socket 13-pole (2x electrical functions E1/ E2 and lighting);&# 160;Operation: Via 2 buttons on the joystick; 1st latching function, 2nd pressing function
- Front socket 13-pole (2x electrical functions E1/ E2 and lighting);&# 160;Operation: Via 2 buttons on the joystick; 1st pressing function, 2nd pressing function
- Front socket 13-pole (2x electrical functions E1/ E2 and lighting);&# 160;Operation: Via 2 buttons on the joystick; 1st latching function, 2nd latching function

Electrical connections in rear

- Rear socket 7-pole for lighting of rear attachments

Electrical system

Battery disconnect switch:

- Battery isolator switch driver's cab - relay isolating

Safety options

- Reversing warning device (acoustic)
- Rear view camera
- Seat belt monitoring
- Immobilizer ignition key (operation: Via coded ignition key)

Custom-made paint finish

- Special painting RAL single-color - instead of Wacker Neuson yellow
- Special painting RAL multi-color

Other

- Floor plate counterweight ({200 kg}{440.9 lb})
- Tool box incl. tool set
- Combination bag (warning triangle / first aid kit)
- Fully automatic central lubrication unit

Warranty extension

- Economy 24 months (2500 h)
- Economy 36 months (3000 h)
- Economy 48 months (3500 h)
- Economy 60 months (4000 h)
- Premium 24 months (3000 h)
- Premium 36 months (4000 h)
- Premium 48 months (5000 h)
- Premium 60 months (6000 h)

Trailer and recovery equipment

- Trailer hitch {38 mm}{1.5 in}, automatic
- Maneuvering coupling (Not approved for trailer operation!)