



DT08

Track Dumper

The rental center professional

With its 1764 payload and only 79 cm machine width, the DT08 is the perfect fit for rental fleets. The low-maintenance and intuitive-to-operate hydrostatic drive system allows simple operation, even for inexperienced operators. At the same time, it is gentle on the subbase due to its wide tracks and the perfectly balanced center of gravity with low ground pressure. The sturdy travel gear design ensures durability and low wear.

Highlights

- Hydrostatic drive
- Small dimensions
- Diesel or gasoline engine

Technical Data

Hydraulic

Hydraulic pump	<input type="checkbox"/> ZRP
Flow rate max.	10.8 gal/mi

Mechanical - Output Details

Travel speed	2.5 m/H
--------------	---------

Mechanical Details

Length	65.4 "
Width	31.1 "
Height	50.2 "
Weight	1,014.13 lb
Payload max.	1,763.7 lb
Skip	<input type="checkbox"/> Front tip skip
Skip capacity levelled	0.4 yd ³
Skip capacity heaped	0.5 yd ³
Operating weight (min.-max.)	1,311.8 - 1,565.3 lb

Engine

Cooling	<input type="checkbox"/> air cooling
---------	--------------------------------------

Engine type	<input type="checkbox"/> Gasoline engine
Cylinder	1.0
Cylinder capacity	16.5 Inch ³
Inclined position max.	20.0 °
Effective power	8.9 hp
Nominal Engine speed	3,600.0 1/min
Engine Manufacturer	<input type="checkbox"/> Honda
Engine Designation	<input type="checkbox"/> GX270

Environment Data

Sound level LpA	87.0 dB(A)
Sound level LpA (Standard)	<input type="checkbox"/> ISO 6396
Sound power LWA, guaranteed	101.0 dB(A)
Sound power LWA (Standard)	<input type="checkbox"/> ISO 6395

Shipping and Storage

Shipping weight	1,146.4 lb
-----------------	------------

Available engines

■ 6,8 kW Diesel engine with electric starter

Cylinder capacity	26.5 Inch3
Effective power	9.1 hp
Stroke	3 "
Bore	3.4 "
Engine type	Diesel engine
Cylinder	1
Engine Manufacturer	Yanmar
Engine Designation	L100AE

Dimensions

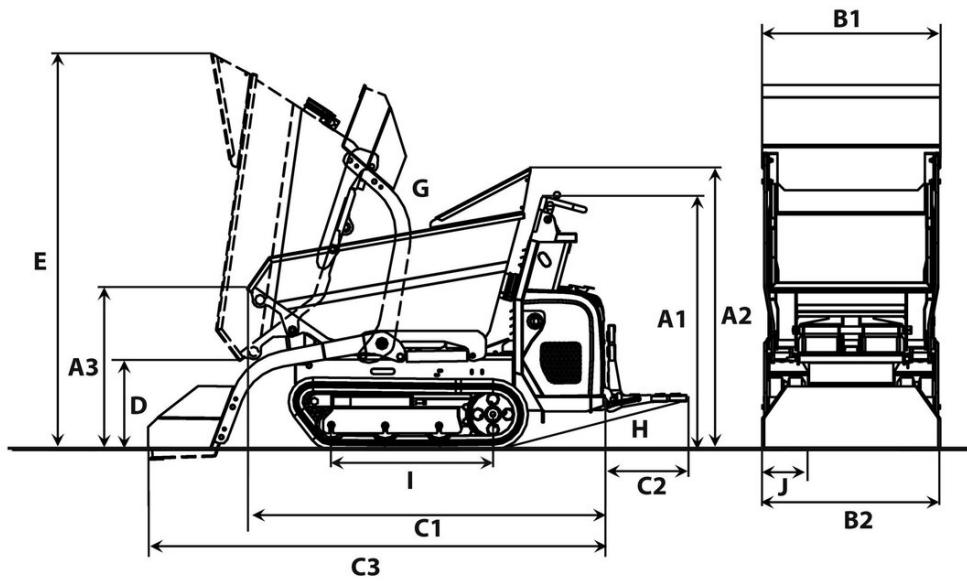

		Front tip skip	High tip skip	Front tip platform
A1	Height above operator's stand	48.9 in	48.9 in	48.9 in
A2	Height over skip hand guard	51.3 in		
A3	Height front edge of skip	29.5 in	38.7 in	31.7 in
	Height front edge of high tip skip raised		62.1 in	
B1	Width of skip	32.4 in	29.8 in	31.5 in
B2	Width of vehicle	31.5 in	31.5 in	31.5 in
	Width with self-loading equipment	32.6 in		
C1	Total length without footboard	70.4 in	65.9 in	73.8 in
C2	Length footboard	15.7 in	15.7 in	15.7 in
C3	Length with self-loading equipment, without footboard	89.1 in		
D	Dumping height max.	16.1 in	30.6 in	8.5 in
	Dumping height max., high tip skip raised		53.4 in	
E	Skip height tilted	72.4 in	75.5 in	54.4 in
	Skip height tilted, high tip skip raised		98.4 in	
I1	Ground clearance	4.3 in	4.3 in	
G	Dumping angle	72 °	82 °	55 °
H	Rollback angle footboard	12 °	12 °	12 °
I	Length chain stand	30.3 in	30.3 in	30.3 in
J	Track width	7.1 in	7.1 in	7.1 in