



8155

Wheel Loader

The powerful flagship.

The Kramer 8155 wheel loader consistently puts the customer's needs first. It impresses with well thought-out details and technical innovations, such as the 7-inch LCD display with integrated rear view camera or the automatic climate control and automatic bucket return. The ergonomics of the cab ensure efficient work and the powerful engine provides the necessary power for daily use.

Powerful engine: The Deutz TCD 3.6 engine powers the wheel loader with 100 kW and complies with exhaust stage V.

Tractor: An EU-wide tractor approval and trailer coupling with 1 t drawbar load ensure the strongest operations.

Comfortable workplace: The cab features ergonomically arranged controls.

Extended loader: A lifting height of up to 4.20 m with perfect visibility of the attachment at the same time.

Perfect all-rounder: The various hydraulic control circuits, an electric socket, a DIN signal socket, as well as an air brake and hydraulic brake provide a variety of options in the rear.

Technical Data

Standard engine data

Engine manufacturer	Deutz
Drive output	100 kW
Drive output	136 PS
Cylinder capacity	3,621 cm ³
Exhaust standard level	V
Exhaust aftertreatment	DOC / DPF / SCR

Weights

Bucket capacity (standard bucket)	1.55 m ³
Payload (max.)	4,200 kg
Operating weight	9,850 - 10,250 kg
Payload (S=1.25)	4,200 kg
Payload (S=1.25 extended loader unit)	3,800 kg
Tipping load (standard bucket)	6,100 kg
Tipping load (pallet fork)	5,250 kg

Filling levels

Tank capacity for fuel	140 l
------------------------	-------

Tank capacity for hydraulic oil 125 l

Drive system

Travel speed Standard	0-20 km/h
Travel speed Option 1	0-30 km/h
Travel speed Option 2	0-40 km/h

Hydraulic system

Work hydraulics discharge volume (max.)	150 l/min
---	-----------

Kinematics

Kinematics type	PZ
-----------------	----

Steering

Steering angle max.	40 degree
---------------------	-----------

Noise characteristic values

Guaranteed sound power level LwA (cabin)	102 dB(A)
Measured sound power level LwA	100.7 dB(A)
Sound pressure level at the operator's ear	70 dB(A)

Dimensions

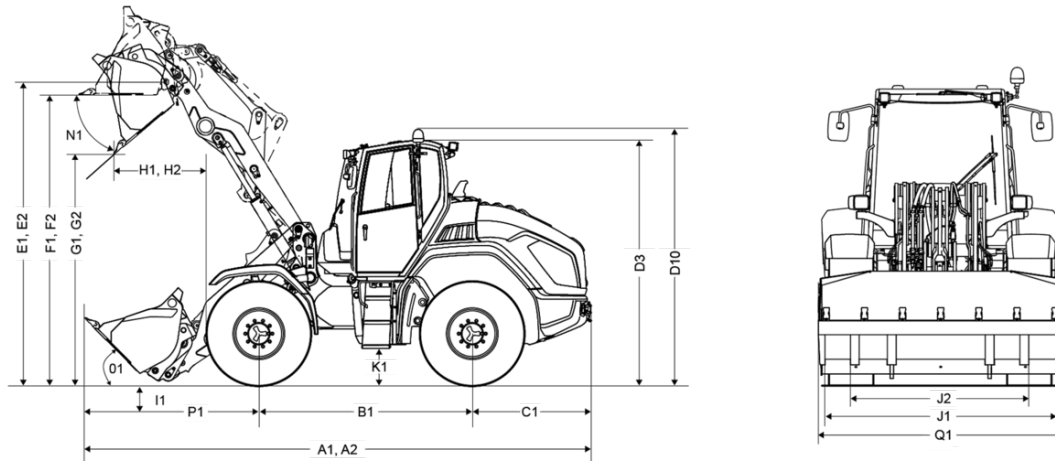

A1	Total length with standard attachment	6,450 mm
A2	Total length with standard attachment / extended loading system	6,970 mm
B1	Wheel base center	2,620 mm
C1	Rear overhang	1,520 mm
D3	Height with cab	3,010 mm
D10	Total height with rotating beacon	3,175 mm
E1	Max. height blade pivot point	3,760 mm
E2	Max. height of hinge pin height / extended loading system	4,200 mm
F1	Load-over height	3,520 mm
F2	Load-over height / extended loading system	3,950 mm
G1	Dumping height	2,725 mm
G2	Dumping height / extended loading system	3,237 mm
H1	Dumping width	1,085 mm
H2	Dumping range / extended loading system	1,275 mm
I1	Digging depth	150 mm
J1	Total width	2,500 mm
J2	Track width	1,955 mm
K1	Ground clearance	445 mm
L1	Turning radius outer edge wheels	3,865 mm
M1	Steering angle	40 °
M2	Swing angle	24 °
N1	Dumping angle at max. lifting height	45 °
O1	Dumping angle at ground level	45 °
P1	Distance center front axle to tooth tip	2,310 mm
Q1	Bucket width	2,500 mm
R1	Stacking height	3,605 mm
R2	Stacking height / extended loading system	4,055 mm