



2080T

Telescopic wheel loaders

Technical Data

■ Standard engine data

Engine manufacturer	Deutz
Motor type	TD 2.9 L4 S5
Cylinder	4
Drive output	45 kW
Drive output	61 HP
at max. rpm	2,300 rpm
Cylinder capacity	176.97 in ³
Type of coolant	Water
Exhaust standard level	V
Exhaust aftertreatment	DOC/DPF
Average sound power level LwA (cabin)	98.8 dB(A)
Guaranteed sound power level LwA (cabin)	100 dB(A)
Specified sound pressure level LpA (cabin)	74 dB(A)

■ Engine data Option 1

Engine manufacturer	Deutz
Motor type	TCD 2.9 L4 S5
Cylinder	4
Drive output	55.4 kW
Drive output	75 HP
at max. rpm	2,300 rpm
Cylinder capacity	176.97 in ³
Type of coolant	Water/charge air
Exhaust standard level	V
Exhaust aftertreatment	DOC/DPF
Average sound power level LwA (cabin)	100 dB(A)
Guaranteed sound power level LwA (cabin)	101 dB(A)
Specified sound pressure level LpA (cabin)	77 dB(A)

■ Electrical system

Operating voltage	12 V
-------------------	------

Battery	100 Ah
Alternator	95 A

■ Weights

Operating weight	10,141 lb
Tipping load with bucket – machine straight, loading frame horizontal	5,983 lb
Tipping load with bucket – machine pivoted, loading frame horizontal	4,982 lb
Tipping load with bucket – machine straight (extended)	3,444 lb
Tipping load with bucket – machine pivoted (extended)	2,855 lb
Tipping load with pallet fork – machine straight, loading frame horizontal	5,254 lb
Tipping load with pallet fork – machine pivoted, loading frame horizontal	4,407 lb
Tipping load with pallet fork – machine straight (extended)	3,208 lb
Tipping load with pallet fork – machine pivoted (extended)	2,674 lb

■ Driver's cab

Driver's cab	Cab
--------------	-----

■ Filling levels

Tank capacity for fuel	19.81 US gal
Tank capacity for hydraulic oil	13.21 US gal

■ Drive system

Type of drive	Hydrostatic
drive unit	universal joint shaft
Speed levels	2
Axle	PA 1200
Travel speed Standard	0-12,43 mph
Travel speed Option 1	0-17,40 mph
Operating brake	Hydrostatic drive system acting on all 4 wheels (wear-free)
Parking brake	Service and parking brake in the drive train acts on all 4 wheels
Differential lock	100 % front axle + rear axle

■ Hydraulic system

Drive hydraulics working pressure (max.)	6527 psi
Work hydraulics discharge volume (max.)	15, 19 (19,55) gpm
Work hydraulics working pressure (max.)	3408 psi

■ Kinematics

Lifting cylinder	1
Tipping cylinder	1
Quick change system	hydraulic

■ Steering

Steering type	Hydraulically activated articulated pendulum steering
Steering cylinder	1
Oscillating angle	±12 degree

■ Other information

FSD = operator's canopy
DPF = diesel particulate filter
DOC = diesel oxidation catalyst
SCR = selective catalytic reduction
Tipping load calculation according to ISO 14397

Dimensions

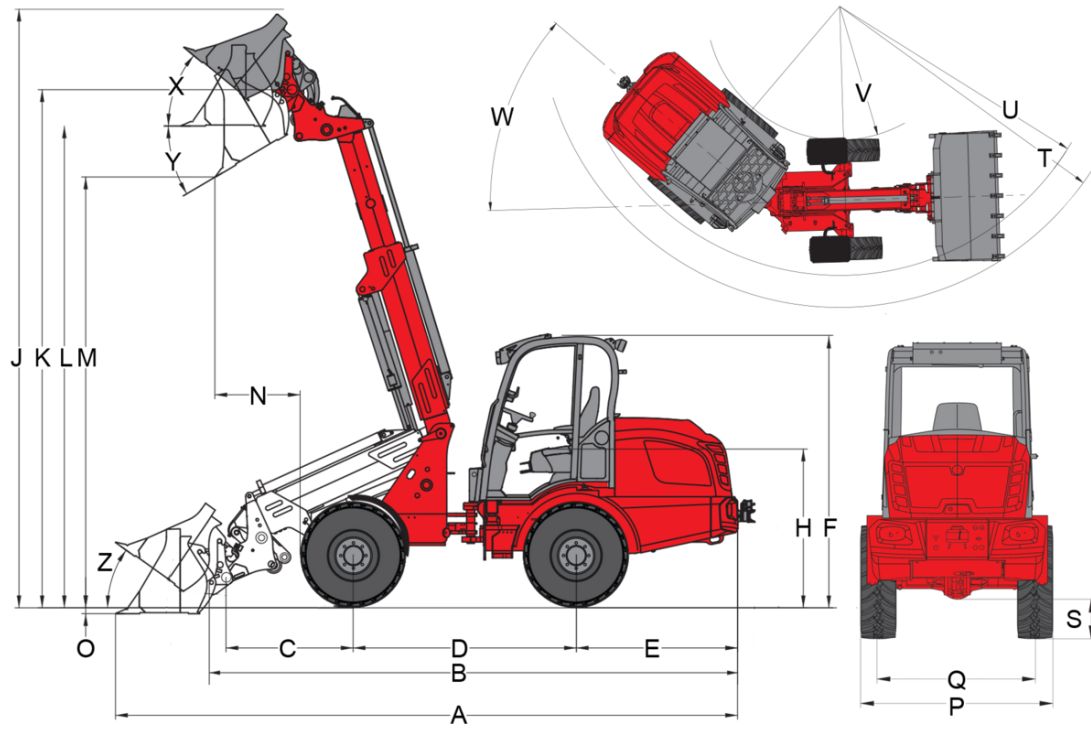

Telescopic arm (Z-kinematics)

	Standard components	11.5/80 - 15.3 AS ET40
A	Total length	216.5 in
B	Total length without bucket	165.0 in
C	Bucket pivot point (to center of axle)	26.8 in
D	Wheel base	80.7 in
E	Rear overhang	55.9 in
F	Height with lowered operator's canopy	
	Height with operator's canopy raised	
	Height with cab lowered	92.9 in
	Height with cab raised	100.0 in
	Height with cab	
H	Seat height	56.3 in
J	Total working height	200.0 in
K	Bucket pivot point (max. lift height)	168.9 in
L1	Load-over height telescopic arm retracted	
L	Load-over height telescopic arm extended	155.1 in
	Load-over height	
M1	Dumping height telescopic arm retracted	
M	Dumping height	
	Dumping height telescopic arm extended	133.9 in
N	Reach (at M)	35.0 in
O	Digging depth	5.9 in
P	Total width	55.5 in
Q	Track width	44.1 in
S	Ground clearance	11.8 in
T	Maximum radius	150.8 in
U	Radius on the outer edge	130.7 in
V	Inner radius	68.1 in
W	Articulation angle	45 °
X	Rollback angle at max. lift height	40 °
Y	Dumping angle	33 °
Z	Rollback angle on ground	32 °

The illustrations, equipment and data shown may deviate from the current delivery program of your country. Optional equipment subject to additional charge may be shown. Subject to changes.