



5065

Wheel Loader

Rugged on the outside and intelligent on the inside.

The all-wheel drive 5065, which has become known as the "650", is a model in the 5 Series and is synonymous with compactness and maneuverability. The bucket volume of 0.65 m³ to 1.1 m³ and the standard Kramer quick-release plate allow unbeatable flexibility for any application. The undivided frame and proven all-wheel steering ensure maximum stability and maneuverability on uneven terrain. Especially in road construction, horticulture and landscaping, the machine is easily able to lift a stone pallet - a special feature in this size class.

Flexible use: A bucket volume from 0.65 m³ to 1.1 m³ depending on material density.

Safety: The convenient and intuitive operation of all functions creates safety, even for novice drivers.

Constant payload: Due to the undivided frame, the vehicle has an unchanged vehicle length which enables a constantly high payload.

Environmentally friendly engine technology: One 35 kW engine with exhaust stage V, as well as DOC and DPF.

Technical Data

Standard engine data

Engine manufacturer	Yanmar
Drive output	34.3 kW
Drive output	46 PS
Cylinder capacity	2,190 cm ³
Exhaust standard level	V
Exhaust aftertreatment	DOC / DPF

Weights

Bucket capacity (standard bucket)	0.65 m ³
Operating weight	3,200 - 4,300 kg
Payload (S=1.25)	1,750 kg
Lift capacity (max.)	32.5 kN
Tipping load (standard bucket)	2,340 kg
Tipping load (pallet fork)	2,187 kg

Filling levels

Tank capacity for fuel	60 l
------------------------	------

Tank capacity for hydraulic oil 58 l

Drive system

Travel speed Standard	0-20 km/h
Travel speed Option 1	0-30 km/h

Hydraulic system

Work hydraulics discharge volume (max.)	56 l/min
---	----------

Kinematics

Kinematics type	P
-----------------	---

Steering

Steering angle max.	35 degree
---------------------	-----------

Noise characteristic values

Guaranteed sound power level L _{wA} (cabin)	101 dB(A)
Measured sound power level L _{wA}	100.3 dB(A)
Sound pressure level at the operator's ear	79 dB(A)

Dimensions

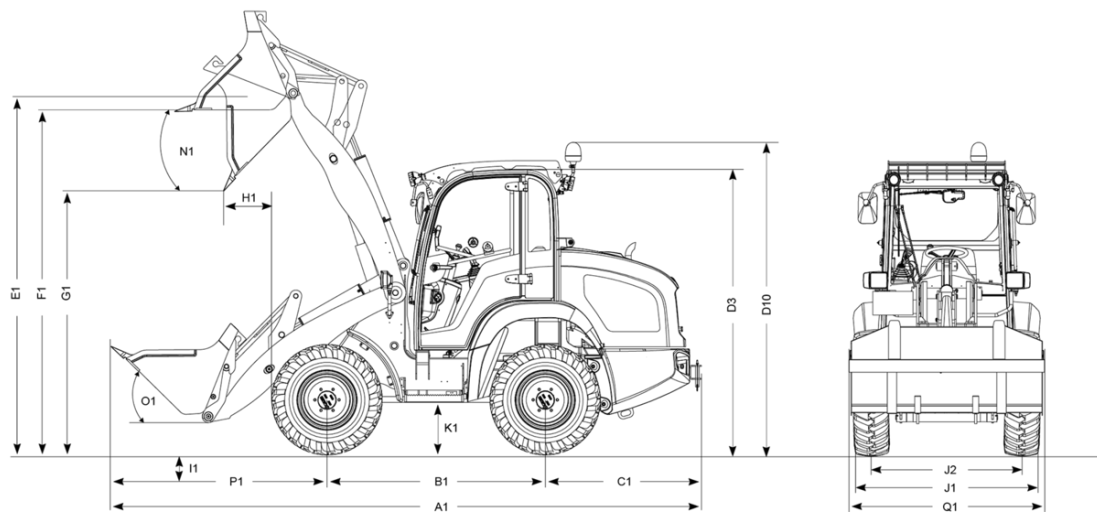

A1	Total length with standard attachment	4,950 mm
A2	Total length with standard attachment / extended loading system	5,140 mm
B1	Wheel base center	1,850 mm
C1	Rear overhang	1,320 mm
D3	Height with cab	2,390 mm
D5	Height of cab with protective grille	2,470 mm
D10	Total height with rotating beacon	2,390 mm
E1	Max. height blade pivot point	3,050 mm
E2	Max. height of hinge pin height / extended loading system	3,300 mm
F1	Load-over height	2,750 mm
F2	Load-over height / extended loading system	3,150 mm
G1	Dumping height	2,310 mm
G2	Dumping height / extended loading system	2,650 mm
H1	Dumping width	315 mm
H2	Dumping range / extended loading system	410 mm
I1	Digging depth	55 mm
J1	Total width	1,590 mm
J2	Track width	1,262 mm
K1	Ground clearance	280 mm
L1	Turning radius outer edge wheels	2,700 mm
M1	Steering angle	38 °
M2	Swing angle	16 °
N1	Dumping angle at max. lifting height	45 °
O1	Dumping angle at ground level	45 °
P1	Distance center front axle to tooth tip	1,780 mm
Q1	Bucket width	1,650 mm
R1	Stacking height	2,950 mm