



## 5085

### Wheel Loader

The down-to-earth all-rounder.

The 5085 5 Series is characterized by its ease of use and functionality. The efficient machine also impresses with its dynamic all-wheel drive, high payload and comparatively low operating weight. With the clearly laid out cab, nothing stands in the way of all-round visibility and even inexperienced drivers quickly find their way around with the simple operating concept. The compact dimensions allow maximum maneuverability, even in tight spaces.

**Long loading system:** An extended mast is available as an option, which makes the machine more flexible in terms of reach and pile height.

**Ride comfort:** The fully automatic load stabilizer dampens vibrations of the loading system or the load and enables a high level of driving comfort at higher speeds.

**Time saving:** The 5085 can reach a maximum speed of 30 km/h with the corresponding power option.

**Exhaust gas stage V:** Exhaust gas aftertreatment takes place through DOC and DPF.

**Drive comfort:** The fully automatic load stabiliser dampens oscillations of the loader unit and/or the load, thus enabling a high level of operator comfort at higher speeds

## Technical Data

### Standard engine data

Engine manufacturer	Rehlko
Drive output	55.4 kW
Drive output	75 PS
Cylinder capacity	2,482 cm <sup>3</sup>
Exhaust standard level	V
Exhaust aftertreatment	DOC / DPF

### Weights

Bucket capacity (standard bucket)	0.85 m <sup>3</sup>
Payload (max.)	1,530 kg
Operating weight	4,610 - 4,693 kg
Payload (S=1.25)	2,250 kg
Lift capacity (max.)	42.9 kN
Tipping load (standard bucket)	3,700 kg
Tipping load (pallet fork)	2,800 kg

### Filling levels

Tank capacity for fuel	75 l
------------------------	------

Tank capacity for hydraulic oil 50 l

### Drive system

Travel speed Standard	0-20 km/h
Travel speed Option 1	0-30 km/h
Differential lock	100% front axle

### Hydraulic system

Work hydraulics discharge volume (max.)	68,4 l/min
---	------------

### Kinematics

Kinematics type	P
Quick change system	hydraulic

### Steering

Steering angle max.	40 degree
---------------------	-----------

### Noise characteristic values

Guaranteed sound power level L <sub>wA</sub> (cabin)	101 dB(A)
Measured sound power level L <sub>wA</sub>	98.2 dB(A)
Sound pressure level at the operator's ear	74 dB(A)

## Dimensions

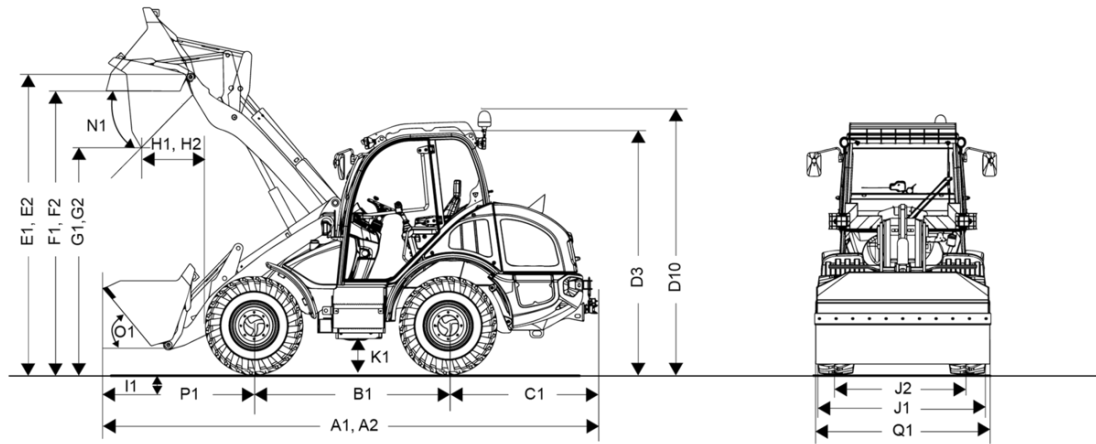

A1	Total length with standard attachment	5,270 mm
A2	Total length with standard attachment / extended loading system	5,580 mm
B1	Wheel base center	2,020 mm
C1	Rear overhang	1,490 mm
D3	Height with cab	2,480 mm
D10	Total height with rotating beacon	2,710 mm
E1	Max. height blade pivot point	3,350 mm
E2	Max. height of hinge pin height / extended loading system	3,499 mm
F1	Load-over height	3,210 mm
F2	Load-over height / extended loading system	3,360 mm
G1	Dumping height	2,680 mm
G2	Dumping height / extended loading system	2,820 mm
H1	Dumping width	580 mm
H2	Dumping range / extended loading system	790 mm
I1	Digging depth	50 mm
J1	Total width	1,740 mm
J2	Track width	1,400 mm
K1	Ground clearance	300 mm
L1	Turning radius outer edge wheels	2,840 mm
M1	Steering angle	40 °
M2	Swing angle	22 °
N1	Dumping angle at max. lifting height	41 °
O1	Dumping angle at ground level	50 °
P1	Distance center front axle to tooth tip	1,860 mm
Q1	Bucket width	1,950 mm
R1	Stacking height	3,150 mm
R2	Stacking height / extended loading system	3,240 mm