



**WACKER
NEUSON**
all it takes!

ET42

Tracked Conventional Excavator

The boost for every construction site

Full speed ahead: the ET42 mini-excavator combines proven technology with a large dose of innovation to lead the 4-metric ton class. It has the usual high lifting and digging forces, as well as fast work cycles. Thanks to modern technologies, emissions are reduced while efficiency is increased. The ET42's powerful engine meets Stage V emissions standards. The intuitive operating concept means this powerhouse is both user-friendly and comfortable for the operator, while offering an excellent view of the working area.

Highlights

- Flexible cylinder rod protection
- Load Sensing Flow Sharing
- Vertical Digging System VDS+
- 3-point kinematics
- Active Working Signal (AWS)

Technical Data

Hydraulic

Operating pressure hydraulics	3,552.5 psi
Hydraulic pump	Axial piston pump
Flow rate max.	23.8 gal/mi

Mechanical - Output Details

Nominal rotation speed	36.0 1/min
Travel speed	3.0 m/H

Mechanical Details

Length	220.2 "
Width	68.9 "
Height	102.7 "
Weight	8,415.05 lb
Operating weight (min.-max.)	8,889.0 - 11,477.3 lb
Digging depth (max.)	139.5 "

Engine

Cooling	Water-cooling
---------	---------------

Engine type	Diesel engine
Cylinder	3.0
Cylinder capacity	101.4 Inch ³
Inclined position max.	30.0 °
Fuel	HVO EN15940
Effective power	43.6 hp
Nominal Engine speed	2,000.0 1/min
Exhaust-gas limit	EU Stage V
Battery capacity (nom. value)	77.0 Ah
Engine Manufacturer	Perkins
Engine Designation	403J-E17T

Environment Data

Sound power LWA, guaranteed	97.0 dB(A)
-----------------------------	------------

Shipping and Storage

Shipping weight	8,415.1 lb
-----------------	------------

Dimensions

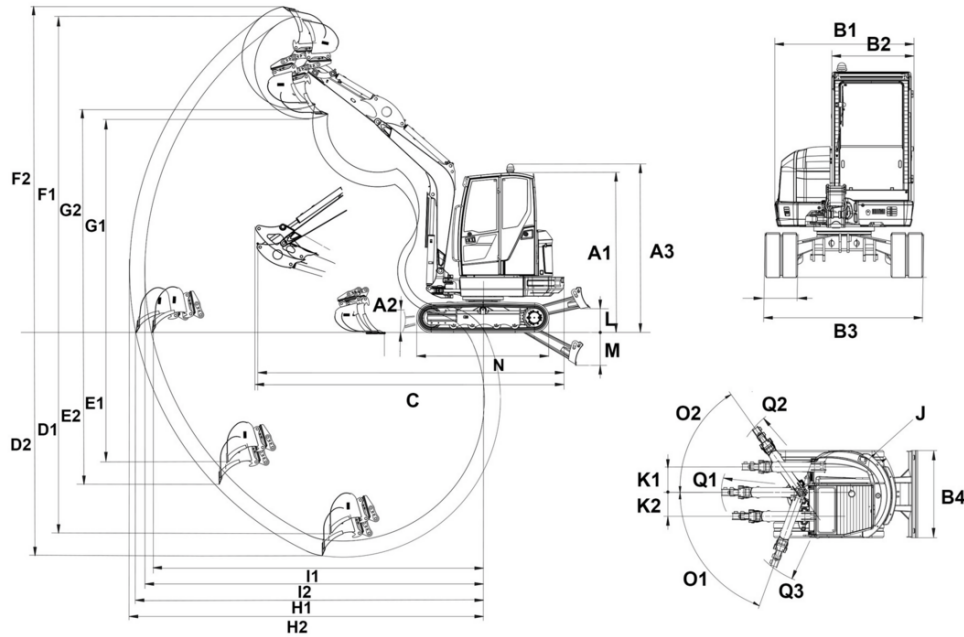

A1	Height with cab	98.26 in
A2	Height of dozer blade	14.2 in
A3	Total height with rotating beacon	102.76 in
B1	Width of upper carriage	67.77 in
B2	Width of cab	38.61 in
B3	Width travel gear	68.95 in
B4	Width of dozer blade	68.95 in
C	Transport length short shovel arm	202.75 in
	Transport length long shovel arm	202.99 in
D1	Digging depth max., short shovel arm	131.75 in
D2	Digging depth max., long shovel arm	139.63 in
E1	Piercing depth max., short shovel arm	83.29 in
E2	Piercing depth max., long shovel arm	90.34 in
F1	Piercing height max., short shovel arm	205.27 in
F2	Piercing height max., long shovel arm	210.4 in
G1	Dumping height max., short shovel arm	140.78 in
G2	Dumping height max., long shovel arm	145.9 in
H1	Digging radius max., short shovel arm	216.27 in
H2	Digging radius max., long shovel arm	223.71 in
I1	Max. reach at ground level (short shovel arm)	211.81 in
I2	Max. reach at ground level (long shovel arm)	219.46 in
J	Tail swing radius	52.6 in
K1	Boom offset max. (to center of bucket right side)	19.42 in
K2	Boom offset max. (to center of bucket left side)	20.96 in
L	Stacking height max. (dozer blade above surface)	16.47 in
M	Digging depth max. (dozer blade below surface)	22.2 in
N	Length travel drive	86.6 in
O1	Max. swivel angle (arm system to the left)	70 °
O2	Max. swivel angle (arm system to the right)	55 °
Q1	Boom swing radius center	85.7 in
Q2	Boom swing radius right	81.2 in
Q3	Boom swing radius left	71.71 in