



KRAMER
on the safe side

5095 Wheel Loader

The down-to-earth powerhouse.

The 5095 machine impresses with its dynamic all-wheel drive and high payload. The bucket volume of 0.95 m³ to 1.5 m³ with low overall height distinguishes the machine in this size class. The efficient high-pressure travel drive enables high thrust forces. In addition, the optional high-speed gear offers further versatile applications.

Bucket volume: The bucket volume of 0.95 m³ to 1.5 m³ with a headroom of less than 2.5 m distinguishes the machine in this size class.

Speed: The 5095 can be equipped with the 30 km/h fast gear.

Long loading system: An extended mast is available, which makes the machine more flexible in terms of reach and pile height.

Exhaust gas stage V: Exhaust gas aftertreatment takes place through DOC and DPF.

Bucket volumes: The bucket volumes of 0.95 m³ to 1.5 m³ with a height of less than 2.5 m characterise the machine in this size class

Technical Data

Standard engine data

Engine manufacturer	Rehiko
Drive output	55.4 kW
Drive output	75 PS
Cylinder capacity	2,482 cm ³
Exhaust standard level	V
Exhaust aftertreatment	DOC / DPF

Weights

Bucket capacity (standard bucket)	0.95 m ³
Payload (max.)	1,710 kg
Operating weight	4,714 - 4,800 kg
Payload (S=1.25)	2,350 kg
Lift capacity (max.)	42.8 kN
Tipping load (standard bucket)	3,800 kg
Tipping load (pallet fork)	2,900 kg

Filling levels

Tank capacity for fuel	75 l
------------------------	------

Tank capacity for hydraulic oil 50 l

Drive system

Travel speed Standard	0-20 km/h
Travel speed Option 1	0-30 km/h
Differential lock	100% front axle

Hydraulic system

Work hydraulics discharge volume (max.)	68,4 l/min
---	------------

Kinematics

Kinematics type	P
Quick change system	hydraulic

Steering

Steering angle max.	40 degree
---------------------	-----------

Noise characteristic values

Guaranteed sound power level LwA (cabin)	101 dB(A)
Measured sound power level LwA	98.2 dB(A)
Sound pressure level at the operator's ear	74 dB(A)

Dimensions

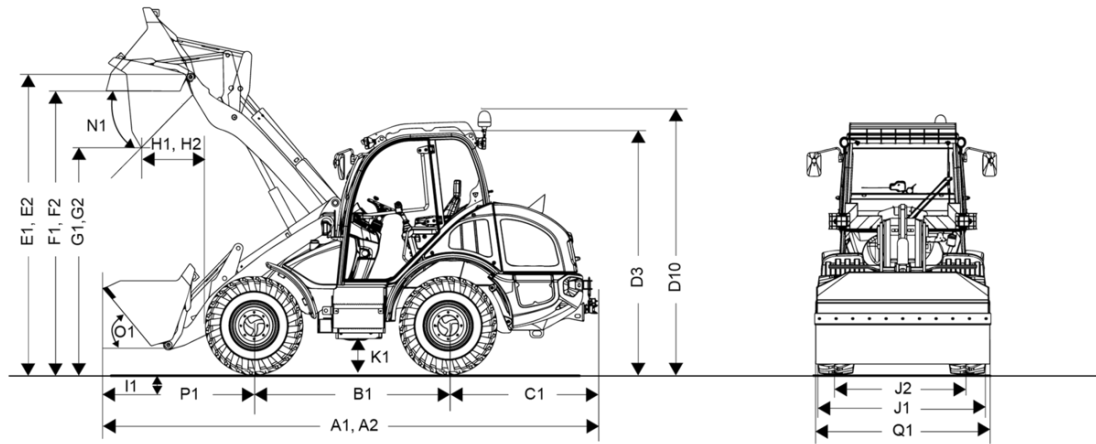

A1	Total length with standard attachment	5,270 mm
A2	extended loading system	5,580 mm
B1	Wheel base center	2,020 mm
C1	Rear overhang	1,490 mm
D3	Height with cab	2,480 mm
D10	Total height with rotating beacon	2,710 mm
E1	Max. height blade pivot point	3,350 mm
E2	Max. height of hinge pin height extended loading system	3,499 mm
F1	Load-over height	3,210 mm
F2	extended loading system	3,360 mm
G1	Dumping height	2,680 mm
G2	extended loading system	2,820 mm
H1	Dumping width	580 mm
H2	extended loading system	790 mm
I1	Digging depth	50 mm
J1	Total width	1,740 mm
J2	Track width	1,400 mm
K1	Ground clearance	330 mm
L1	Turning radius outer edge wheels	2,840 mm
M1	Steering angle	40 °
M2	Swing angle	22 °
N1	Dumping angle at max. lifting height	41 °
O1	Dumping angle at ground level	50 °
P1	Distance center front axle to tooth tip	1,860 mm
Q1	Bucket width	1,950 mm
R1	Stacking height	3,150 mm
R2	extended loading system	3,290 mm

Standard components

Cab

- Soundproofed, vibration-insulated, 4-point suspension cab with large and deep-drawn thermal glazing, rear heated windshield
- Mechanically-sprung seat (MSG85/722) with automatic seat belt; weight, back and horizontal adjustment
- Incline-adjustable steering column
- 3-stage powerful heating and ventilation and defroster nozzles on the windshield
- Color-coded keypads for hydraulic, electric, driving and safety functions
- Large, fold-over, exterior mirror on both sides
- Interior mirror, sun shade, cabin lighting, 12 V outlet
- Lighting according to road traffic regulations
- Work lights 2x LED Basic on front, 2x LED Basic on rear (1000 Lumen)
- Inspected according to ROPS and FOPS I

Engine

- Battery disconnect switch
- 4 years or 4,000 operating hours warranty on the engine

Power transmission

- "Smart Driving" rpm reduction
- Combined brake-inch pedal
- 100% self-locking differential connectable in the front axle
- Mechanical parking brake
- Lubrication line for pendulum pins

Steering and work hydraulics

- Hydrostatic all-wheel steering with emergency steering properties
- Mechanical pilot-operated joystick for lifting/lowering and filling/emptying the loader unit function with a rocker switch for selecting the travel direction as well as an integrated 3rd control circuit (proportional control) and functional lighting integrated into the joystick

Kinematics

- Hydraulic quick-hitch plate
- Parallel kinematics
- Load hook on the tipping bar
- Visual position indicator for bucket and fork

Documentation

- Operator's manual, service manual

Options

Cab

- Cabin with heated rear windshield, incl. door contact switch (standard)
- Cab with heated rear window and windshield in door glass to the left, including door contact switch
- Air-sprung operator's seat (6830KM/855NTS) with heated seat
- Operator's seat (MSG85/721) with faux leather cover
- Radio system (radio, antenna, speaker)
- Radio installation
- Air-conditioning system
- 2-step entry
- Rotating beacon LED
- Document box
- Protective faux leather cover, loose
- Automatic orange seatbelt

Lighting

- High gear 30 km/h incl. Smart Driving
 - only in association with
 - Load stabilizer (vibration damper)
 - License plate illumination, including license plate bracket in front
 - Front-wheel-drive and crab steering
- Front-wheel-drive and crab steering
- Low-speed device (CSD) and hand throttle

The illustrations, equipment and data shown may deviate from the current delivery program of your country. Optional equipment subject to additional charge may be shown. Subject to changes.

Approval, road traffic

- Data confirmation (ABE) for self-propelled work machine (standard)*

* Germany, Luxembourg, Netherlands, Austria, Slovakia, Czech Republic, Switzerland, Estonia, Latvia, Lithuania, Hungary

Drive system & Axles

In conjunction with a ball hitch, the rear outlet must always be selected

- Ball head coupling (K50) - fixed to frame
- Automatic towing hitch 38 mm - fixed to frame

Tires

- Load stabilizer (vibration damper)
- Loading system with increased lifting height (payload and bucket volume may be reduced)
- Quick-hitch facility, fully hydraulic, "Smart Attach", system Kramer HV/WL-C
- Hydraulic quickhitch facility, system Euro (technical data and available attachments differ)
- Hydraulic quickhitch facility, Volvo Z
 - not with:
 - Loading system with increased lifting height (payload and bucket volume may be reduced)
- Hydraulic quickhitch facility, system Skid Steer

Loading system & Quick coupler system

- Pressure release of 3rd control circuit
- Floating position
- Unpressurized return line, front, including overflow oil line
- Filling of the hydraulic system with environmentally-friendly hydraulic oil; PANOLIN Synt46
- Engine oil and hydraulic oil pre-heating (230 V)
- only in association with
- Kohler KDI2504TCR LRC
- Engine pre-heating, fuel and hydraulic oil (230 V)

Hydraulics

- Floating position
- Unpressurized return line, front, including overflow oil line
- Filling the hydraulic system with environmentally friendly and biodegradable hydraulic fluid

Electrical system

- Reversing alarm (acoustic)
- Pipe-break protection for lift and tilting cylinders
- Warning stripes red / white (according to DIN 30710)
- EquipCare Dual ID
- Immobilizer system, integrated in the ignition switch key
- Fire extinguisher (2 kg)
- Protective measures for use in corrosive environments (use of salt and fertilizer)
- Safety support lifting cylinder
- Tire blow-out protection
- Cardan shaft wrap guard

Safety options

- Central lubrication point
- Special painting in one color according to RAL (gray parts are not included) *
- (Fully automatic) central lubrication unit
 - not with:
 - Protective measures for use in corrosive environments (use of salt and fertilizer)
- Central lubrication system (corrosive environments)
- Salt spreader Polaro 170 I
- Set of tools
- Tool box
 - not with:
 - Warning stripes red / white (according to DIN 30710)
- Combination case (first aid kit, warning triangle, reflective vest)

* We reserve the right to reject paint jobs which show similarities to protected colors or color combinations from other manufacturers.

Paint

- Michelin 400/70 R18 BIBLOAD (restricted steering angle 38°) - multi-purpose tread profile
- Michelin 340/80 R18 BIBLOAD - multi-purpose tread profile
- Alliance 340/80 R18 Multiuse 550 - municipal tread profile
- Mitas Premium 375/70 R20 AC70G - traction tread profile
- Michelin 340/80 R18 XMCL- traction tread profile
- Continental 335/80 R20 MPT81 - multi-purpose tread profile
- Firestone 340/80 R18 Duraforce
- Firestone 405/70 R18 Duraforce

Other

- Security 24 (2000 h)
- Security 36 (3000 h)
- Security 48 (3000 h)
- Security 48 (4000 h)
- Security 48 (5000 h)
- Security 60 (4000 h)
- Security 60 (5000 h)
- Power-Line (24 months or 2000 h)
- Power-Line (36 months or 3000 h)
- Power-Line (48 months or 3000 h)
- Power-Line (48 months or 4000 h)
- Power-Line (48 months or 5000 h)
- Power-Line (60 months or 4000 h)
- Power-Line (60 months or 5000 h)

Extended warranties

- Security 24 (2000 h)
- Security 36 (3000 h)
- Security 48 (4000 h)
- Security 60 (5000 h)