



8085T

Telescopic wheel loaders

HIGH FLYER IN OPTIONS

The powerful 8085T is equipped with a 55 kW Deutz engine as standard. Due to the narrow box construction of the telescopic loader unit, optimal visibility is provided. The telescopic wheel loader enables a greater reach, as well as stacking and dumping height. Furthermore, the one-piece chassis of this model also provides a constant payload and stability.

Work hydraulics: The load-independent flow distribution (LUDV) ensures parallel execution of different hydraulic functions

Telescopic loading system: Increased productivity thanks to increased reach, stacking and dumping height as well as an optimum overview thanks to the narrow box design

Panoramic cabin: The optional panoramic cabin provides maximum visibility upwards

Four operating modes: Power, Eco, Road, and CSD - the right and fuel-saving driving setting for every application

Smart Attach: Hydraulic attachments can be changed quickly, simply, and safely as a result of the series' installed full-hydraulic quickhitch plate

Technical Data

Standard engine data

Engine manufacturer	Deutz
Drive output	55.4 kW
Drive output	75 PS
Cylinder capacity	2,924 cm ³
Exhaust standard level	V
Exhaust aftertreatment	DOC / DPF

Weights

Bucket capacity (standard bucket)	0.85 m ³
Payload (max.)	1,530 kg
Operating weight	5,700 - 6,600 kg
Payload (S=1.25)	2,100 kg
Tipping load (standard bucket)	3,300 kg
Tipping load (pallet fork)	2,625 kg

Filling levels

Tank capacity for fuel	85 l
Tank capacity for hydraulic oil	50 l

Drive system

Travel speed Standard	0-20 km/h
Travel speed Option 1	0-30 km/h
Travel speed Option 2	0-40 km/h
Differential lock	100 % front axle + rear axle

Hydraulic system

Work hydraulics discharge volume (max.)	90 l/min
---	----------

Kinematics

Kinematics type	Z
Quick change system	Kramer HV/WL-C; includes Smart Attach

Steering

Steering angle max.	40 degree
---------------------	-----------

Noise characteristic values

Guaranteed sound power level LwA (cabin)	101 dB(A)
Measured sound power level LwA	99.4 dB(A)
Sound pressure level at the operator's ear	74 dB(A)

Dimensions

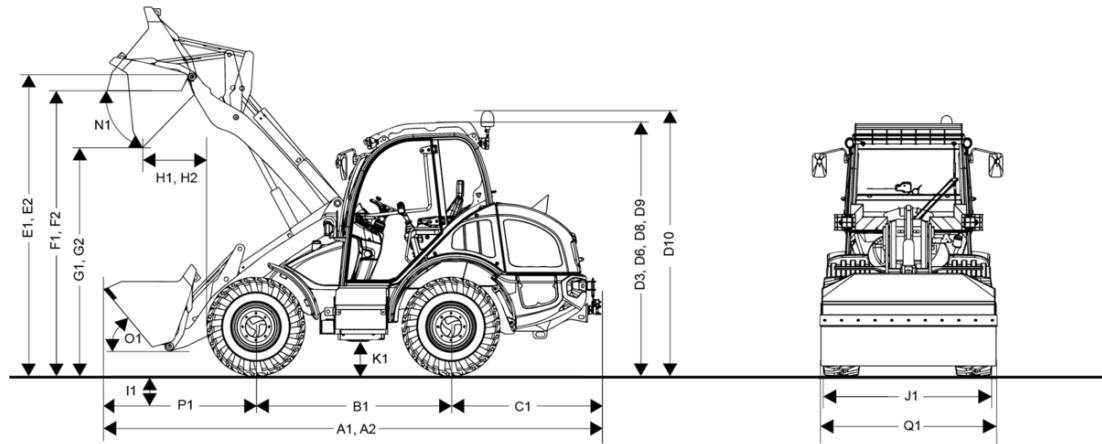

A1	Total length with standard attachment	5,955 mm
B1	Wheel base center	2,020 mm
C1	Rear overhang	1,490 mm
D3	Height with cab	2,490 mm
D6	Height with air-conditioning system	2,575 mm
D8	Height with panoramic cab	2,530 mm
D9	Height with panoramic cab and air-conditioning system	2,575 mm
D10	Total height with rotating beacon	2,765 mm
E1	Max. height blade pivot point: retracted	3,730 mm
E2	Max. height blade pivot point : extended	4,825 mm
F1	Load-over height: retracted	3,520 mm
F2	Load-over height: extended	4,620 mm
G1	Dumping height: retracted	3,010 mm
G2	Dumping height: extended	4,100 mm
H1	Dumping width: retracted	600 mm
I1	Digging depth	45 mm
H2	Dumping width: extended	1,060 mm
J1	Total width	1,780 mm
K1	Ground clearance	330 mm
L1	Turning radius outer edge wheels	2,840 mm
M1	Steering angle	40 °
M2	Swing angle	22 °
N1	Dumping angle at max. lifting height: retracted	40 °
N2	Dumping angle at max. lifting height: extended	40 °
O1	Dumping angle at ground level	41 °
P1	Distance center front axle to tooth tip	2,456 mm
Q1	Bucket width	1,950 mm
R1	Stacking height: retracted	3,490 mm
R2	Stacking height: extended	4,590 mm