



ST45

Compact Track Loader

Lift Higher, Load More

The ST45 is a large versatile machine. The vertical lift arm makes it perfect for unloading pallets of pavers or stone from trucks and distributing them around the jobsite. The 74hp regeneration-free engine provides easy maintenance and no interruptions to the workday, meaning more up time and greater productivity.

Highlights

- Controls for Every Operator
- Two-speed transmission
- 5.7-inch Color Display
- Forward Tipping Cab
- Maximum Visibility

Technical Data

Hydraulic

Flow rate	83.0 l/min
Flow rate max.	119.0 l/min
Auxiliary hydraulics relief pressure	240.0 bar

Mechanical - Output Details

Ground Pressure	0.3 bar
Breakout force - tilt	31,275.0 kN
Breakout force - lift	36,298.0 N
Tractive Effort max. at 100% effective force	49,280.0 N
Travel speed stage 1	10.3 km/h
Travel speed stage 2	15.5 km/h

Mechanical Details

Operating weight	4,679.0 kg
------------------	------------

Engine

Cooling	Water-cooling
---------	---------------

Engine type	Diesel engine
Cylinder	4.0
Cylinder capacity	3,400.0 cm ³
Oil filling max.	15.6 l
Operating power	55.4 KW
Operating Engine speed	2,500.0 1/min
Battery capacity (nom. value)	950.0 Ah
Engine Manufacturer	Kohler

Operating Fluids

Hydraulic fluid volume	40.0 l
Fuel Tank capacity	133.0 l

Chassis

Tip Load	4,082.0 kg
Rated Operating Capacity at 35% Tip Load	1,429.0 kg

Dimensions

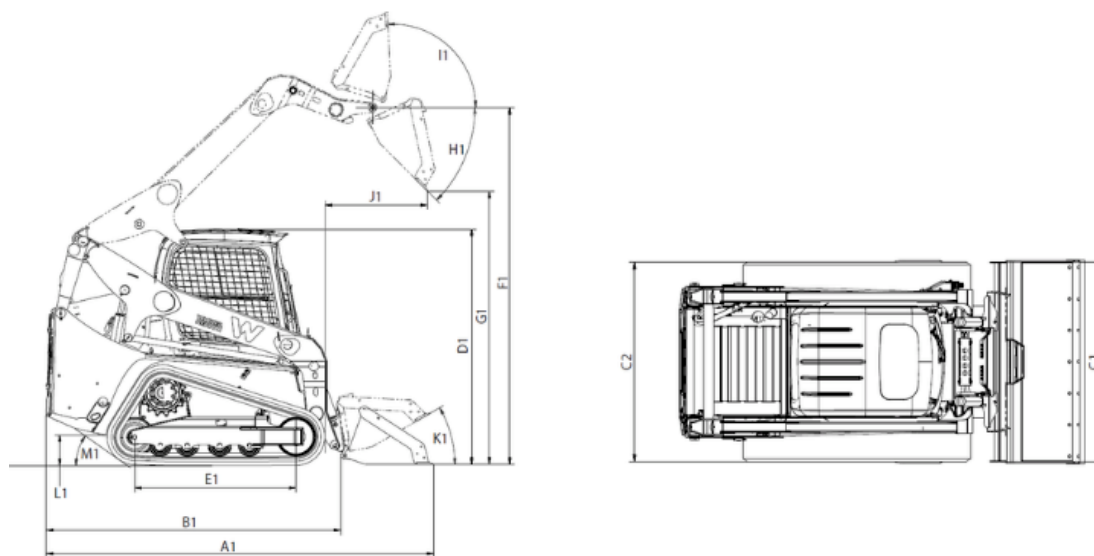

A1	Overall length with bucket	3,794 mm
B1	Overall length without bucket	3,048 mm
C1	Overall width with bucket	2,045 mm
D1	Overall height	2,150 mm
F1	Hinge pin height	3,463 mm
G1	Dump height max.	2,755 mm
H1	Dump angle	40 °
I1	Bucket rollback at max. stroke height	94 °
J1	Dump reach	943 mm
L1	Ground clearance	272 mm
M1	Angle of departure	29 °
C2	Overall length without bucket	1,982 mm
E1	Length of track on ground	1,631 mm
K1	Bucket rollback at ground level	30 °