



DT12

Track Dumper

Works efficiently everywhere

The hydraulically activated and pilot-operated machine provides for overall simple operation, and the hydrostatic drive system make it a comfortable and durable machine for a variety of job site applications. Rubber tracks provide excellent weight distribution and low ground pressure even with a high payload. The extensive selection of skips, a low center of gravity and the suspension-mounted rollers make it an ideal material handler on all types of terrain.

Highlights

- Hydrostatic drive
- Small dimensions

Technical Data

Hydraulic

Hydraulic pump	<input type="checkbox"/> Variable displacement and gear pump
Flow rate max.	76.0 l/min

Mechanical - Output Details

Travel speed	4.0 km/h
--------------	----------

Mechanical Details

Length	1,823.0 mm
Width	790.0 mm
Height	1,303.0 mm
Weight	650.00 kg
Payload max.	1,200.0 kg
Skip	<input type="checkbox"/> Front tip skip
Skip capacity levelled	393.0 l
Skip capacity heaped	440.0 l
Operating weight (min.-max.)	685.0 - 940.0 kg

Engine

Engine type	<input type="checkbox"/> Diesel engine
-------------	--

Cylinder	3.0
Cylinder capacity	719.0 cm ³
Inclined position max.	20.0 °
Effective power	12.0 KW
Nominal Engine speed	2,700.0 1/min
Exhaust-gas limit	<input type="checkbox"/> EU Stage V
Engine Manufacturer	<input type="checkbox"/> Kubota
Engine Designation	<input type="checkbox"/> D-722
Stroke	68.0 mm
Bore	67.0 mm

Environment Data

Sound level LpA	88.0 dB(A)
Sound level LpA (Standard)	<input type="checkbox"/> ISO 6396
Sound power LWA, guaranteed	101.0 dB(A)
Sound power LWA (Standard)	<input type="checkbox"/> ISO 6395

Shipping and Storage

Shipping weight	610.0 kg
-----------------	----------

Dimensions

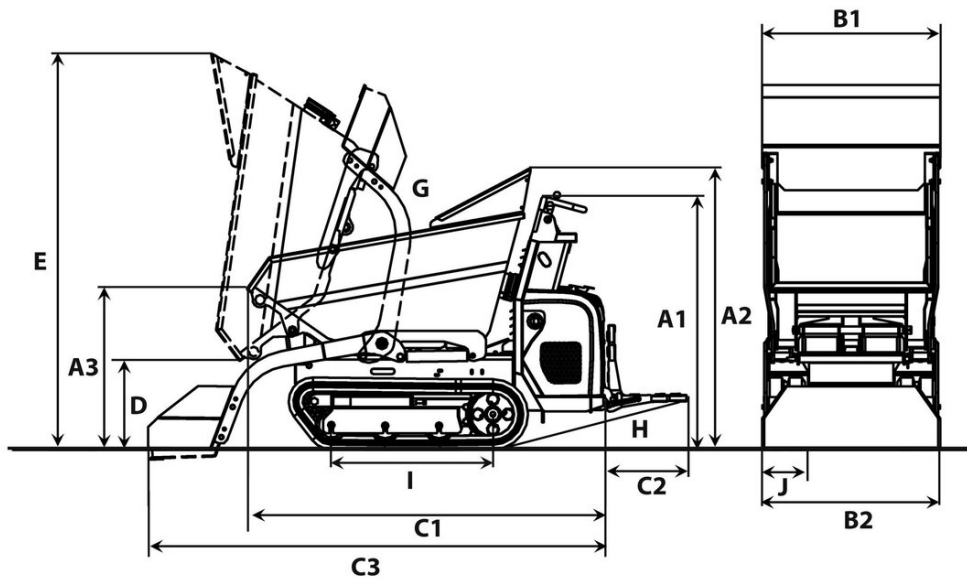

		Front tip skip	High tip skip	Swivel tip skip	Front tip platform
A1	Height above operator's stand	1,280 mm	1,280 mm	1,280 mm	1,280 mm
A3	Height front edge of skip	812 mm	1,110 mm	1,060 mm	850 mm
	Height front edge of high tip skip raised		1,715 mm		
B1	Width of upper carriage	700 mm	800 mm	730 mm	800 mm
	Width of skip	830 mm	830 mm	782 mm	800 mm
B2	Width of undercarriage	790 mm	790 mm	790 mm	790 mm
C1	Total length without footboard	1,823 mm	1,684 mm	1,960 mm	1,882 mm
C2	Length footboard	393 mm	393 mm	393 mm	393 mm
C3	Length with self-loading equipment, without footboard	2,277 mm	2,240 mm		
D	Dumping height max.	460 mm	868 mm	650 mm	256 mm
	Dumping height max., high tip skip raised		1,467 mm		
E	Skip height tilted	1,950 mm	2,009 mm	2,112 mm	1,430 mm
	Skip height tilted, high tip skip raised		2,610 mm		
G	Dumping angle	70 °	82 °	85 °	56 °
H	Rollback angle footboard	14 °	14 °	14 °	14 °
I	Length chain stand	875 mm	875 mm	875 mm	875 mm