



9580T

Telescopic wheel loaders

Technical data

■ Electrical system

Operating voltage	12 V
Battery	185 Ah
Alternator	120 A

■ Weights

Operating weight	11,210 kg
Tipping load with bucket – machine straight, loading frame horizontal	6,594 kg
Tipping load with bucket – machine pivoted, loading frame horizontal	5,871 kg
Tipping load with bucket – machine straight (extended)	3,495 kg
Tipping load with bucket – machine pivoted (extended)	3,112 kg
Tipping load with pallet fork – machine straight, loading frame horizontal	5,775 kg
Tipping load with pallet fork – machine pivoted, loading frame horizontal	5,142 kg
Tipping load with pallet fork – machine straight (extended)	3,265 kg
Tipping load with pallet fork – machine pivoted (extended)	2,907 kg

■ Driver's cab

Driver's cab	Cab
--------------	-----

■ Filling levels

Tank capacity for fuel	140 l
Tank capacity for hydraulic oil	125 l
Tank capacity for urea solution	12 l

■ Drive system

Type of drive	Hydrostatic
drive unit	universal joint shaft
Speed levels	3
Axle	PA 1900
Travel speed Standard	0-20 km/h

Travel speed Option 1	0-30 km/h
Travel speed Option 2	0-40 km/h
Operating brake	Multi-disc brake on front axle acting on rear axle via universal joint shaft
Parking brake	Electro-hydraulic multi-disc brake with spring suspension on the front axle, acting on rear axle via universal joint shaft
Differential lock	100 % front axle + rear axle

■ Hydraulic system

Drive hydraulics working pressure (max.)	480 bar
Work hydraulics discharge volume (max.)	150 (180) l/min
Work hydraulics working pressure (max.)	250 bar

■ Kinematics

Lifting cylinder	1
Tipping cylinder	1
Quick change system	hydraulic

■ Steering

Steering type	Hydraulic articulated joint with oscillating axle
Steering cylinder	2
Oscillating angle of the rear axle	± 12 degree

■ Noise characteristic values

Average sound power level LwA (cabin)	100.7 dB(A)
Guaranteed sound power level LwA (cabin)	102 dB(A)
Specified sound pressure level LpA (cabin)	70 dB(A)

■ Standard engine data

Engine manufacturer	Deutz
Motor type	TCD 3.6 S5
Cylinder	4
Drive output	100 kW

Drive output	136 PS
at max. rpm	2,300 U/min
Cylinder capacity	3,621 cm ³
Type of coolant	Water/charge air
Exhaust standard level	V
Exhaust aftertreatment	DOC/DPF/SCR

■ **Engine data Option 1**

Engine manufacturer	Deutz
---------------------	-------

Motor type	TCD 4.1 S5
Cylinder	4
Drive output	156 PS
at max. rpm	2,300 U/min
Cylinder capacity	4,038 cm ³
Type of coolant	Water/charge air
Exhaust standard level	V
Exhaust aftertreatment	DOC/DPF/SCR

Dimensions

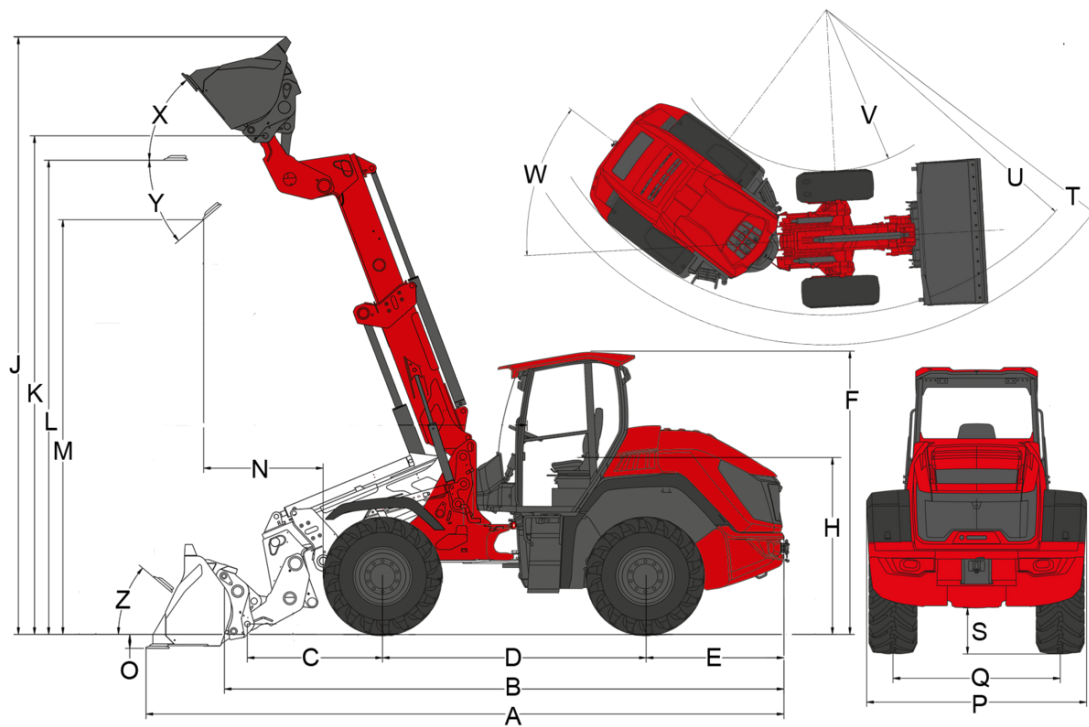

Telescopic arm (Z-kinematics)

A	Total length	6,960 mm
B	Total length without bucket	6,090 mm
C	Bucket pivot point (to center of axle)	1,440 mm
D	Wheel base	2,900 mm
E	Rear overhang	1,520 mm
F	Height with cab	3,110 mm
H	Seat height	1,940 mm
J	Total working height	6,500 mm
K	Bucket pivot point (max. lift height)	5,480 mm
L1	Load-over height telescopic arm retracted	4,070 mm
L	Load-over height telescopic arm extended	5,210 mm
M1	Dumping height telescopic arm retracted	3,440 mm
M	Dumping height telescopic arm extended	4,580 mm
N	Reach (at M)	1,300 mm
O	Digging depth	130 mm
P	Total width	2,390 mm
Q	Track width	1,820 mm
S	Ground clearance	502 mm
T	Maximum radius	5,770 mm
U	Radius on the outer edge	4,900 mm
V	Inner radius	2,450 mm
W	Articulation angle	40 °
X	Rollback angle at max. lift height	50 °
Y	Dumping angle	40 °
Z	Rollback angle on ground	40 °

Standard components

Engine

- Deutz TCD 3.6 S5, 100 kW / 136 hp, stage V

Steering system

- Hydraulic articulated steering with pendulum axle, pendulum angle (axle) $\pm 12^\circ$
- Steering cylinder: 2

Tires

- 500 / 70 R24 Michelin XMCL ET 40, profile XMCL, width 2390 mm, height 3110 mm

Operator's cab

- Comfort 2-door cab, ROPS/FOPS Level 2
- Air conditioning with automatic climate control
- Sliding windows in both doors
- Roof window with wiper
- Radio DAB+
- 7" color display for all important machine information
- Rear view camera
- Heated rear window

Operator's seat

- Fully damped comfort seat with safety belt, weight, back and height adjustment

Lighting

- Lighting according to StVZO
- LED working lights, 4in front, 2 in rear on cab roof

Drive system & Axles

- Axle: Planetary axle PA1900
- Drive: hydrostatic via PTO gear and driveshaft
- Differential lock: 100 % front and rear axle
- Speed: 20 km/h
- Driving speeds: 3 | 7 km/h / 15 km/h / 20 km/h (optional 30 / 40)
- Service brake: Multi-disc brake in the front axle via driveshaft acting on the rear axle.
- Parking brake: Electro-hydraulic multi-disc brake with spring brake in the front axle, acting on the rear axle via driveshaft.

Loading system

- Telescopic arm lifting height 5480 mm
- Quick-change device according to ISO 23727 (Volvo TPV system) hydraulic
- Kinematics: Z
- Lifting cylinder: 1
- Tilting cylinder: 1
- Automatic bucket return:

Hydraulics

- Electrically pre-controlled joystick with direction switch and integrated button for differential lock
- 3rd Front control circuit electrically pilot-controlled via joystick proportional
- Oil quantity adjustment via jog dial
- Pressure relief of hydraulic connections on loading swing arm

Other

- Reversible fan
- Front socket 13-pin (2x electric functions E1/ E2 and lighting), (Operation:
- Tool box
- Tool kit

StVZO – equipment

- Data confirmation (ABE) for self-propelled working machine

EquipCare (telematics)

- EquipCare 36 months (incl. App & Manager)

Options

Operator's cab

- Outside mirrors heatable and electrically adjustable
- Parking heater incl. engine preheating, programmable
- Document box
- Control panel holder on B-pillar
- Holder for cell phone
- Driving signal socket 7-pin for salt spreader

Operator's seat

- Fabric seat; air suspension (MSG95AL/722)
- Fabric seat; air suspension; heated seats (MSG95AL/722)

Lighting

- Worklights on cab roof, 4 front, 2 rear, 2 rear lateral
- Worklights LED cab roof, 4 front, 2 rear, 2 rear lateral
- Working light LED telescopic arm, 2 front
- Rotating beacon (yellow), (National regulations must be observed!)
- Rotating beacon LED (yellow), (The national regulations must be observed!)

StVZO - equipment

- License plate illumination, including license plate bracket in front

Engine

- Deutz TCD 4.1 S5, 115 kW / 156 hp, stage V
- Preheating engine, fuel, hydraulic oil (230V)

Drive system & Axles

- 30 km/h Power Drive 370
- 30 km/h Power Drive 370 thrust increase
- 40 km/h Power Drive 370
- Dual-line, pressure air-brake system
- Manual inching (slow speed device) and manual throttle
- Gas pedal mode (M-Drive)
- Winding protection for PTO shaft

Tires

- 500/70R24 Michelin XMCL ET40, width 2390 mm, height 3110 mm
- 500 / 70 R 24 164 A8 Duaforce UT, width 2399 mm, height 3125 mm
- 500 / 70 R 24 Trelleborg TH500 ET40, width 2320 mm, height 2910 mm
- 500/70R24 Michelin BIBL. ET40, width 2320 mm, height 2910 mm
- 540/70R24 Michelin BIBL. ET0, width 2463 mm, height 3130 mm
- 540/70R24 Michelin XMCL. ET0, width 2458 mm, height 3137 mm
- 600 / 55 - 26.5 Alliance 331 ET0, width 2487 mm, height 3126 mm
- 17.5 R 25 Michelin X-Mine ET50, width 2280 mm, height 2950 mm
- Tire blow-out protection

Loading system

- Load swing damping
- Vibrating function Tilting cylinder
- Lowering brake valve (pipe breakage protection lifting and tipping cylinder)

Hydraulics in front

- Front pressureless return (incl. leakage oil line)
- 3rd Control circuit Load Sensing 180 l/min, working hydraulic
- 4th Control circuit electrically proportional
- High flow - power hydraulics double-acting 150 l/min
- High flow - power hydraulics single-acting (180 l/min)

Hydraulics in rear

- Pressure-free reverse travel in rear (including overflow oil line)
- Auxiliary control circuit rear tipper (40 l/min) single acting (one coupling)
- One hydraulic connection rear (40 l/min) double-acting (two couplings) incl. tipper connection
- Two rear hydraulic connections (40 l/min) double-acting (four couplings)

Bio-hydraulic oil

- Shell PANOLIN S4 HLP Synth 46 (bio hydraulic oil)

Electrical connections in front

- Socket front 13-pin (2x electric functions E1/ E2 and lighting), (Operation: Via 2 buttons on the joystick; 1st Function push-button, 2nd Function latching)
- Socket front 13-pin (2x electric functions E1/ E2 and lighting), (Operation: Via 2 buttons on the joystick; 1st Function latching, 2nd Function push-button)
- Socket front 13-pin (2x electric functions E1/ E2 and lighting), (Operation: Via 2 buttons on the joystick; 1st Function push-button, 2nd Function push-button)
- Socket front 13-pin (2x electric functions E1/ E2 and lighting), (Operation: Via 2 buttons on the joystick; 1st Function latching, 2nd Function latching)

Electrical connections in rear

- Rear 7-pin socket for lighting rear attachments
- Rear 3-pin socket

Safety options

- Reversing warning device (acoustic)
- Warning stripes red / white (according to DIN 30710)
- Protection package industry
- Immobilizer (operation via coded ignition key)
- Identification plate triangular

Other

- Combination bag (warning triangle / first aid kit)
- Fully automatic central lubrication unit
- Central lubrication system, fully-automatic (aggressive media), (screw fittings and connections made from stainless steel)
- Protective measures for use in aggressive materials (salt and fertilizer use)
- Overseas transportation protection

Warranty extension

- Economy 24 months (2500 h)
- Economy 36 months (3000 h)
- Economy 48 months (3500 h)
- Economy 60 months (4000 h)
- Premium 24 months (3000 h)
- Premium 36 months (4000 h)
- Premium 48 months (5000 h)
- Premium 60 months (6000 h)

Custom-made paint finish

- Special painting RAL single color - instead of Weidemann red

Trailer and recovery equipment

- Automatic attachment coupling
- Bearing block for attachment coupling
- Automatic attachment coupling, height-adjustable for bearing block
- Ball hitch attachment coupling K50, height-adjustable for bearing block
- Piton-Fix attachment coupling, height-adjustable for bearing block
- Attachment coupling CUNA D3, height-adjustable for bearing block
- Front ballast (620 kg)

- EC tractor approval (for Germany)
- EC tractor approval