



## 8095T

### Telescopic wheel loaders

#### HIGH FLYER WITH MAXIMUM COMFORT

The 8095T is part of the Kramer 8 premium series and combines maximum safety and comfort with a great provision of options. The one-piece chassis of the machine provides a high level of maneuverability and constant payload. The narrow box construction of the telescopic loader unit ensures optimal visibility. The machine is optionally available with a 74 kW Deutz engine and the ecospeed transmission.

**Panoramic cabin:** The optionally available front windshield that has been extended upwards guarantees an ideal view of the attachment when the loader unit is extended

**Work hydraulics:** The load-independent flow distribution (LUDV) ensures parallel execution of different hydraulic functions

**Driving modes:** The operator can select the right operating mode (Power, Eco, Road, CSD) for every driving situation

**Smart Attach:** The fully-hydraulic quickhitch plate, installed as standard, makes it possible to comfortably hitch up hydraulic attachments without needing to exit the machine

**Telescopic loading system:** Increased productivity thanks to increased reach, stacking and dumping height as well as an optimum overview thanks to the narrow box design

## Technical Data

### Standard engine data

Engine manufacturer	Deutz
Drive output	55.4 kW
Drive output	75 PS
Cylinder capacity	2,924 cm <sup>3</sup>
Exhaust standard level	V
Exhaust aftertreatment	DOC / DPF

### Weights

Bucket capacity (standard bucket)	0.95 m <sup>3</sup>
Payload (max.)	1,710 kg
Operating weight	6,000 - 6,800 kg
Payload (S=1.25)	2,400 kg
Tipping load (standard bucket)	3,700 kg
Tipping load (pallet fork)	3,000 kg

### Filling levels

Tank capacity for fuel	120 l
Tank capacity for hydraulic oil	64 l

### Drive system

Travel speed Standard	0-20 km/h
Travel speed Option 1	0-30 km/h
Travel speed Option 2	0-40 km/h
Differential lock	100 % front axle + rear axle

### Hydraulic system

Work hydraulics discharge volume (max.)	90 l/min
---	----------

### Kinematics

Kinematics type	Z
Quick change system	Kramer HV/WL-C; includes Smart Attach

### Steering

Steering angle max.	40 degree
---------------------	-----------

### Noise characteristic values

Guaranteed sound power level LwA (cabin)	101 dB(A)
Measured sound power level LwA	98.8 dB(A)
Sound pressure level at the operator's ear	74 dB(A)

## Dimensions

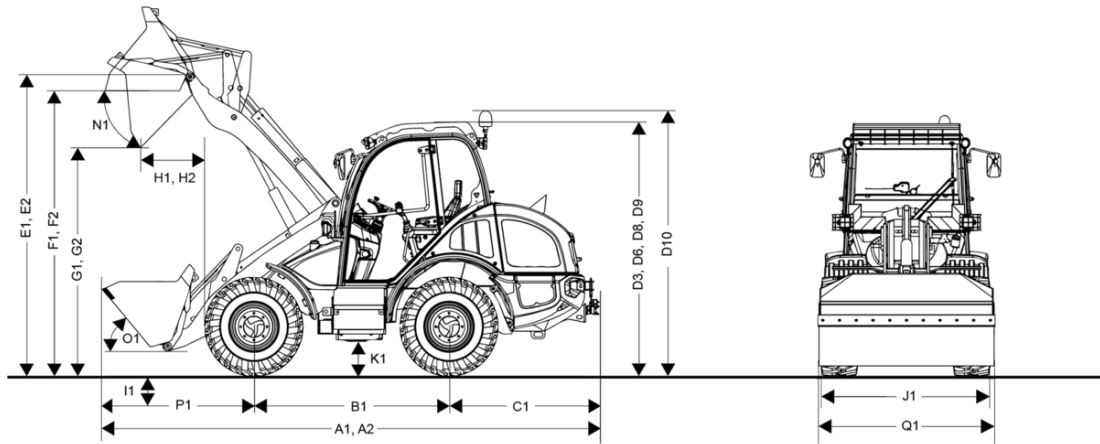

A1	Total length with standard attachment	6,133 mm
B1	Wheel base center	2,150 mm
C1	Rear overhang	1,620 mm
D3	Height with cab	2,690 mm
D6	Height with air-conditioning system	2,735 mm
D8	Height with panoramic cab	2,650 mm
D9	Height with panoramic cab and air-conditioning system	2,735 mm
D10	Total height with rotating beacon	2,925 mm
E1	Max. height blade pivot point: retracted	3,745 mm
E2	Max. height blade pivot point : extended	4,840 mm
F1	Load-over height: retracted	3,540 mm
F2	Load-over height: extended	4,630 mm
G1	Dumping height: retracted	3,020 mm
G2	Dumping height: extended	4,120 mm
H1	Dumping width: retracted	550 mm
I1	Digging depth	50 mm
H2	Dumping width: extended	980 mm
J1	Total width	1,970 mm
K1	Ground clearance	350 mm
L1	Turning radius outer edge wheels	3,000 mm
M1	Steering angle	40 °
M2	Swing angle	22 °
N1	Dumping angle at max. lifting height: retracted	40 °
N2	Dumping angle at max. lifting height: extended	40 °
O1	Dumping angle at ground level	41 °
P1	Distance center front axle to tooth tip	2,375 mm
Q1	Bucket width	2,050 mm
R1	Stacking height: retracted	3,500 mm
R2	Stacking height: extended	4,600 mm