



KL20.5T

Telescopic wheel loader

More range. More efficiency.

The KL20.5T is the perfect all-rounder that adapts to your work - powerful, robust and reliable in daily use. This makes it the ideal introduction to the world of telescopic wheel loaders. The compact design combined with impressive performance is ideal for use in confined spaces - whether in agriculture, gardening and landscaping or on construction sites. With its powerful 33 kW engine, a maximum speed of 30 km/h and an operating weight of over 3,000 kg, it offers the perfect balance of agility and stability.

Telescopic loading system: Increase in productivity due to the plus of transmission range, stacking and dumping height, as well as an optimal overview due to the narrow box structure

Get in and drive away: Thanks to its one-piece vehicle frame, high level of stability, manoeuvrability and constant payload, as well as the three types of steering (all-wheel, crab and front-wheel steering), the machine is easy to operate, even for inexperienced operators

Compact dimensions: Due to its compact dimensions with a vehicle width of 1.32 m, the KL20.5T is ideal for confined working conditions, like narrow farm tracks. With the optional maximum tyres with a 400 mm width, the machine is impressive as a result of its greatest possible contact area and therefore provides optimal stability for demanding applications

Cabin versions: Two full-featured wheel loader cabins, comfort cabin (2.26 m height) and low cabin (2.11 m height), provide excellent 360° visibility, as well as ergonomically designed operating elements for easy and intuitive operation. The wide entry enables the comfortable and quick entry and exit - ideal for daily use

Versatile quickhitch plates: The fully hydraulic quickhitch system Smart Attach is optionally available and makes it possible to change attachments directly from the cabin. Alternative quickhitch plates are also available, like the Euro System

Technical Data

Standard engine data

Engine manufacturer	Yanmar
Drive output	33.3 kW
Drive output	45 PS
at max. rpm	2,600 U/min
Cylinder capacity	1,568 cm ³
Exhaust standard level	V

Weights

Bucket capacity (standard bucket)	0.45 m ³
Stacking height (max.)	3,770 mm
Operating weight	3,050 - 3,300 kg
Payload (S=1.25)	1,240 kg
Tipping load (standard bucket)	1,910 kg
Tipping load (pallet fork)	1,550 kg

Filling levels

Tank capacity for fuel	56 l
------------------------	------

Tank capacity for hydraulic oil 19 l

Drive system

Travel speed Standard	0-20 km/h
Travel speed Option 1	0-30 km/h

Hydraulic system

Work hydraulics discharge volume (max.)	40+37 l/min
---	-------------

Kinematics

Kinematics type	Z
Quick change system	hydraulic

Steering

Steering angle max.	38 degree
---------------------	-----------

Noise characteristic values

Guaranteed sound power level L _{WA} (cabin)	101 dB(A)
Measured sound power level L _{WA}	99.1 dB(A)
Sound pressure level at the operator's ear	77 dB(A)

Dimensions

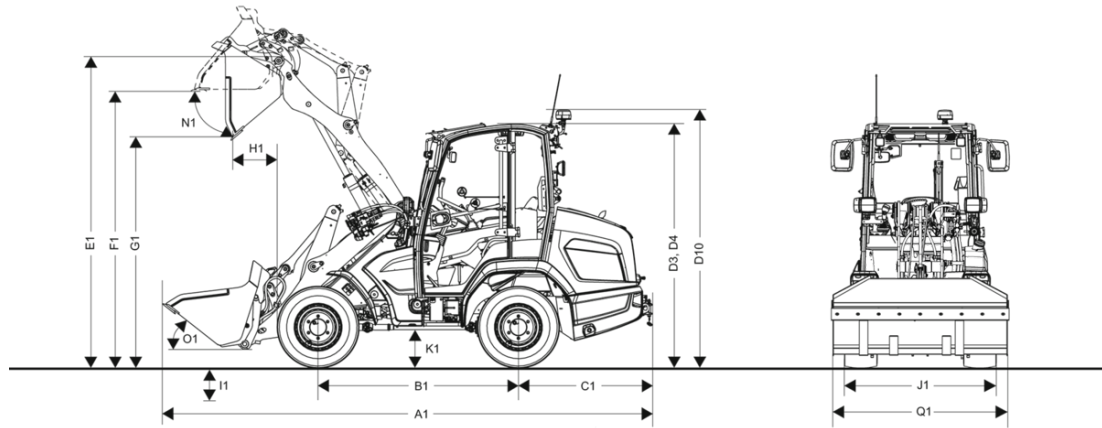

A1	Total length with standard attachment	4,880 mm
B1	Wheel base center	1,860 mm
C1	Rear overhang	1,215 mm
D3	Height with cab	2,260 mm
D4	Height with cab lowered	2,110 mm
D10	Total height with rotating beacon	2,390 mm
E1	Max. height blade pivot point retracted	3,134 mm
E2	Max. height blade pivot point extended	3,888 mm
F1	Load-over height retracted	2,910 mm
F2	Load-over height extended	3,670 mm
G1	Dumping height retracted	2,420 mm
G2	Dumping height extended	3,170 mm
H1	Dumping width retracted	540 mm
H2	Dumping width extended	910 mm
I1	Digging depth	55 mm
J1	Total width	1,320 mm
K1	Ground clearance	230 mm
L1	Turning radius outer edge wheels	2,430 mm
M1	Steering angle	38 °
N1	Dumping angle at max. lifting height retracted	40 °
O1	Dumping angle at ground level	40 °
Q1	Bucket width	1,350 mm
R1	Stacking height retracted	3,020 mm
R2	Stacking height extended	3,770 mm

Standard components

Cab

- Standard cabin with heating
- Rear-view mirror in the cabin
- Automatic turn-signal resetting
- Color-coded keypads for hydraulic, electric, driving and safety functions
- Mechanically-sprung operator's seat with faux leather cover (MSG85/721) with automatic seat belt; weight, back and horizontal adjustment
- Inspected according to ROPS and FOPS I
- Work lights 2x LED Basic on front, 2x LED Basic on rear (1000 Lumen)
- Lighting according to road traffic regulations

Power transmission

- Lubrication line for oscillating pin rear axle
- Combined brake/inch pedal
- Mechanical parking brake
- 100% differential lock front axle

Steering and work hydraulics

- End position synchronization
- Hydrostatic all-wheel steering with emergency steering properties
- Joystick, 3. Electric control circuit with continuous function, with roller switch for selecting the direction of travel

Kinematics

- Z-kinematics with optimized parallel guidance
- Hydraulic quick-change device

Documentation

- Operator's manual, service manual

Options

Operator's cab & Cabine

- Cabin with heating
 - possible seat options:
 - MSG85/721 fabric
 - MSG85/721 imitation leather
 - MSG75GL/521 Luft Heizung
- Low cabin with heating
 - possible seat options:
 - MSG20 Fabric mech. spring
 - MSG20 Mechanical spring
 - MSG75GL/521 Luft Heizung
- Air conditioning
- Heated exterior mirrors right left
- Windshield heating front rear
- Swivel steering column
- Radio preparation
- Radio with DAB reception

Lighting

- Rotating LED beacon (orange)
- 2x LED Basic front work lights (series)
- 2x LED Basic rear work lights (series)
- LED Performance work lights package (4400 lumen)
 - includes:
 - 2x LED Performance front work lights (4400 lumen)
 - 2x LED Performance rear work lights (4400 lumen)

Approval, road traffic

- License plate illumination, including license plate bracket
- Data confirmation (ABE) for self-propelled work machine (standard)*

*Germany, Luxembourg, Netherlands, Austria, Slovakia, the Czech Republic, Switzerland, Estonia, Latvia, Lithuania, Hungary

Drive system & Axles

- Steering mode changeover
- 100 % differential lock front axle (standard)
- Slow speed device CSD and hand throttle
 - includes:
 - Power, Eco, Pedal/CSD mode
 - Driving speed 20 km/h (standard)
 - Driving speed 30 km/h
 - only in conjunction with:
 - Steering mode changeover
 - License plate lighting incl. license plate holder
 - Automatic load stabilizer

Tires

- 31x15.5-15 BKT SPHD ET-10
- 10.0/75 15.3 BKT AS 504 ET55 (standard)
- 10.0-16.5 BKT SkidPower ET50
- BKT 31x15.50-15 BKT TR-313 ET-10
- 315/55R16 Conti MPT81 ET40

Loading system & Quick coupler system

- Automatic load stabilizer
- Floating position
- Fully hydraulic quick-change device
- Smart Attach (fully hydraulic quick-change device)
 - only in conjunction with:
 - Pressure relief 3. Steering committee
- Quick-change system ISO23206 (EURO) HV
 - not in connection with:
 - Load hook
- Weidemann quick-change system
 - not in connection with:
 - Load hook
- Load hook
 - not in connection with:
 - Quick-change system ISO23206 (EURO) HV
 - Weidemann quick-change system
- Standard loading system (Z-kinematics) - (standard)

Hydraulics

- Hydraulic oil Shell PANOLIN S4 HLP Synth 46
- Pressure relief 3. Steering committee
- Preheating package
 - includes:
 - Preheating cooling water 230V
 - Preheating fuel
 - Preheating hydraulic oil

Hydraulics - front area

- Power hydraulics High Flow 69l/min
 - not in connection with:
 - Front return line unpressurized return leakage oil
- Front return line unpressurized return leakage oil
 - not in connection with:
 - Power hydraulics High Flow 69l/min
- Front changeover valve 3. Steering committee
 - not in conjunction with:
 - Power hydraulics High Flow 69l/min
 - Rear changeover valve 3. Steering committee

Hydraulics - rear area

- Rear changeover valve 3. Steering committee
 - not in conjunction with:
 - Front changeover valve 3. Steering committee

Electrical system

- Rear socket 13-pin
- 7-pin front socket outlet
- Battery disconnecter Plus disconnecting external

Safety options

- Reversing warning device (snorer)
- Pipe rupture protection for lift and tilt cylinders (standard)
- Immobilizer, integrated in the ignition key
 - not in connection with:
 - EquipCare Dual ID
- Seat belt warning system
 - not in connection with:
 - Safety belt orange
 - MSG75GL/521 Luft Heizung
- Safety belt orange
 - not in connection with:
 - Seat belt warning system
 - MSG75GL/521 Luft Heizung
- Fire extinguisher (2 kg)
- Warning stripes red / white (DIN30710)
- Sliding lacquer telescopic arm

Paint

- Special paint finish in one color according to RAL (grey parts are not included) *
- Vehicle use Aggressive media (salt and fertilizer use)

* We reserve the right to reject paint finishes that are similar to protected colors or color combinations from other manufacturers!

Other

- Central lubrication system
- Wheel wedge
- EquipCare 36 Mo
- EquipCare Dual ID
 - not in connection with:
 - Immobilizer, integrated in the ignition key

Ball hitches

- Shunting coupling *
- Ball head trailer coupling (K50) - frame-mounted *

*A rear socket must always be selected in conjunction with a trailer coupling (not a maneuvering coupling)!

*Shunting/ball head coupling can only be fitted to the vehicle independently of each other!

Extended warranties

- Security 24 (2000 H)
- Security 36 (3000 H)
- Security 48 (4000 H)
- Security 60 (5000 H)
- Power-Line (24 months or 2000 H)
- Power-Line (36 months or 3000 H)
- Power-Line (48 months or 4000 H)
- Power-Line (60 Monate oder 5000 H)