



ST27

Compact Track Loader

Small But Fierce

The ST27 offers a compact design, outstanding visibility and operator comfort features that make it a perfect fit for any job. The trim package, low weight and ability to lift heavier loads, compared to similar machines in this class, make it especially productive for smaller job sites. The ST27 is powered by a Kohler turbocharged engine offering high horsepower, superior torque and large fuel capacity to operate longer and get more done. The vertical lift arms allow excellent lift and dump height for maximum efficiency and flexibility on the job site.

Highlights

- Controls for Every Operator
- Two-speed transmission
- 5.7-inch Color Display
- Maintenance and Filter Free After-treatment
- Expansive Maintenance Access

Technical Data

Hydraulic

Flow rate	19.3 gal/mi
Flow rate max.	28.8 gal/mi
Auxiliary hydraulics relief pressure	3,480.0 psi

Mechanical - Output Details

Ground Pressure	4.4 psi
Breakout force - tilt	5,404,183.6 lbf
Breakout force - lift	4,783.3 lbf
Tractive Effort max. at 100% effective force	7,476.9 lbf
Bucket Roll Back	2.1 s
Bucket Roll Out	2.2 s
Lift Arm Raise	3.3 s
Lift arm lower	2.8 s
Travel speed stage 1	6.4 m/H
Travel speed stage 2	9.1 m/H

Mechanical Details

Operating weight	7,350.2 lb
------------------	------------

Engine

Cooling	Water-cooling
Cylinder	4.0
Oil filling max.	2.5 gal US
Power rating max.	74.3 hp
Operating Engine speed	2,600.0 1/min
Starter battery Voltage	12.0 V
Engine Manufacturer	Kohler
Engine Designation	KDI2504TCR

Operating Fluids

Hydraulic fluid volume	30.6 qt US
Fuel Tank capacity	27.2 gal US

Chassis

Tip Load	5,401.3 lb
Rated Operating Capacity at 35% Tip Load	1,889.4 lb

Dimensions

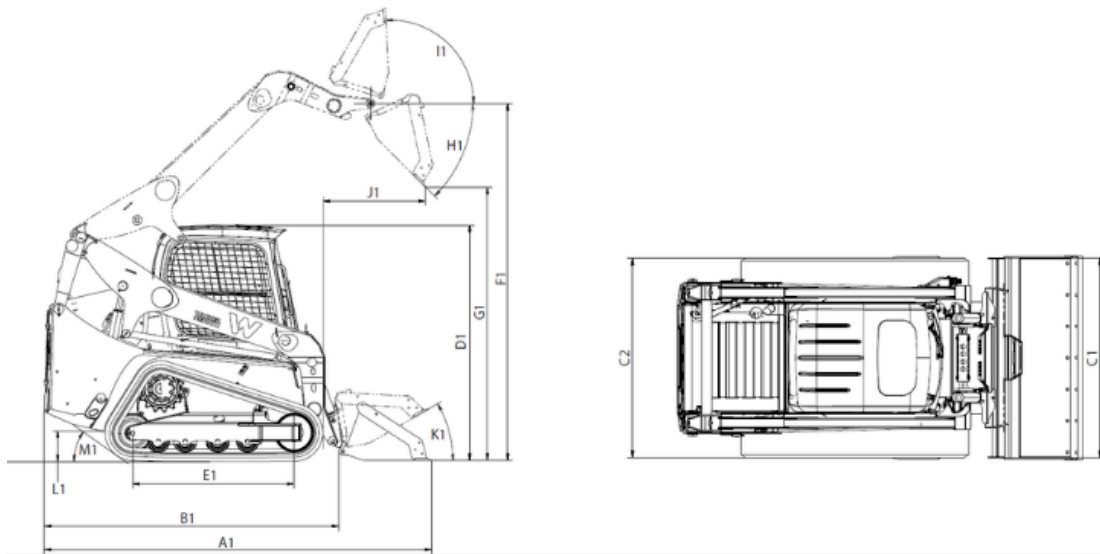

A1	Overall length with bucket	132 in
B1	Overall length without bucket	102.5 in
C1	Overall width with bucket	63.5 in
C2	Overall width without bucket	60 in
D1	Overall height	79.8
E1	Length of track on ground	53.2 in
F1	Hinge pin height	120 in
G1	Dump height max.	94.3 in
H1	Dump angle	37 °
I1	Bucket rollback at max. stroke height	95.5 °
J1	Dump reach	39.2 in
K1	Bucket rollback at ground level	30 °
L1	Ground clearance	8.5 in
M1	Angle of departure	29.9 °