



EZ17e

Tracked Zero Tail Excavator

Fully electric and full performance

The EZ17e is the first fully electric Zero Tail mini-excavator without rear projection. Due to its zero emissions, it is ideal for indoor applications, as well as in areas where exhaust emissions and noise are restricted. Thanks to the powerful lithium ion battery, it can be used for a typical workday and, if necessary, continue to be used in stationary operation connected to a power source. Due to its patented battery technology with integrated battery heating, the unit can be charged at any power source (100 to 415 volts). This can be done without additional extra work being required and independently of the ambient temperature.

Highlights

- Patented battery technology
- Reduced maintenance and service costs
- No exhaust emissions, clearly less noise
- Intuitive operating concept
- 100 % Zero Tail

Technical Data

Hydraulic

Operating pressure hydraulics	240.0 bar
Hydraulic pump	Variable displacement pump
Flow rate max.	39.0 l/min

Mechanical - Output Details

Travel speed	4.5 km/h
--------------	----------

Mechanical Details

Length	3,584.0 mm
Width	980.0 mm
Height	2,365.0 mm
Operating weight (min.-max.)	1,797.0 - 2,151.0 kg
Digging depth (max.)	2,483.0 mm

Motor

Nominal power	16.50 KW
---------------	----------

Nominal current	430.0 A
Nominal voltage	48.0 V
Nominal speed	2,200.0 1/min

Environment Data

Sound level LpA	70.0 dB(A)
Sound power LWA, guaranteed	84.0 dB(A)

Electrical System

Type of battery	Li-Ion
-----------------	--------

Operating Fluids

Hydraulic fluid volume	23.6 l
------------------------	--------

Shipping and Storage

Shipping weight	1,681.0 - 2,036.0 kg
-----------------	----------------------

Dimensions

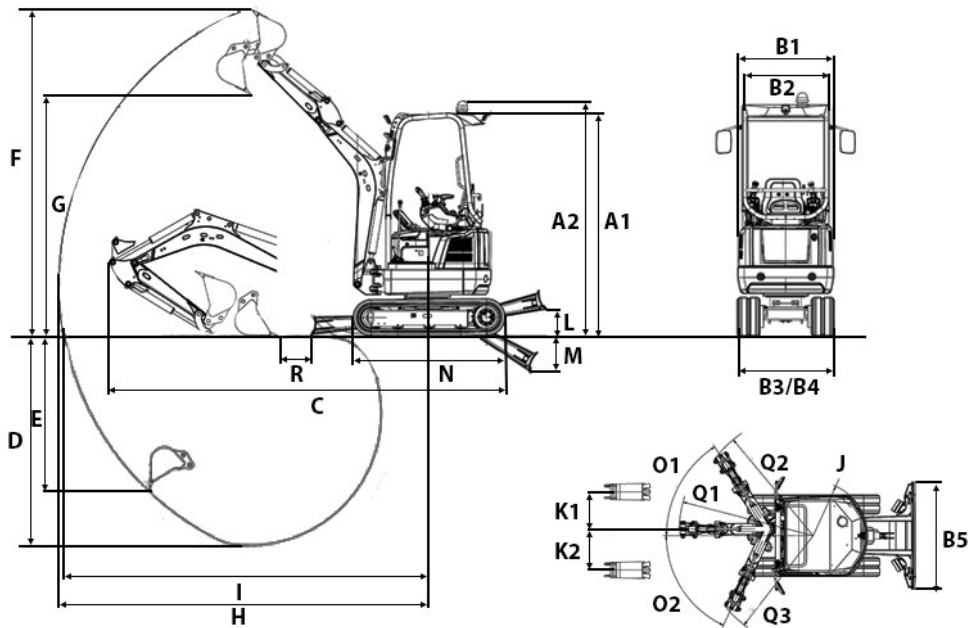

A1	Height of canopy	2,365 mm
A2	Total height with rotating beacon	2,489 mm
B1	Width of upper carriage	980 mm
B2	Width of cab	884 mm
B3	Width travel gear	1,300 mm
B4	Width travel gear retracted	990 mm
B5	Width of dozer blade	1,300 mm
C	Transport length short shovel arm	3,584 mm
	Transport length long shovel arm	3,554 mm
D	Digging depth max., short shovel arm	2,323 mm
	Digging depth max., long shovel arm	2,483 mm
E	Piercing depth max., short shovel arm	1,710 mm
	Piercing depth max., long shovel arm	1,860 mm
F	Piercing height max., short shovel arm	3,465 mm
	Piercing height max., long shovel arm	3,579 mm
G	Dumping height max., short shovel arm	2,439 mm
	Dumping height max., long shovel arm	2,553 mm
H	Digging radius max., short shovel arm	3,900 mm
	Digging radius max., long shovel arm	4,050 mm
I	Max. reach at ground level (short shovel arm)	3,848 mm
	Max. reach at ground level (long shovel arm)	4,001 mm
J	Tail swing radius	660 mm
K1	Boom offset max. (to center of bucket right side)	533 mm
K2	Boom offset max. (to center of bucket left side)	418 mm
L	Stacking height max. (dozer blade above surface)	271 mm
M	Digging depth max. (dozer blade below surface)	390 mm
N	Length travel drive	1,607 mm
O1	Max. swivel angle (arm system to the left)	65 °
O2	Max. swivel angle (arm system to the right)	57 °
Q1	Boom swing radius center	1,635 mm
Q2	Boom swing radius right	1,519 mm
Q3	Boom swing radius left	1,372 mm
R	Distance bucket dozer blade, short shovel arm	331 mm