



## KL38.8

### Wheel loaders

#### EXTERNALLY ROBUST AND INTERNALLY COMFORTABLE

The Kramer KL38.8 is a wheel loader of the Premium 8 Series range and is equipped with the tried-and-tested principle of the one-piece frame. Alongside the great maneuverability, the machine is impressive in both performance and comfort. The optionally available ecospeed transmission, the tractor approval, and the trailer coupling enable efficient operation in any situation. The modern cab design with the fold-down armrest is also impressive in terms of ergonomics and comfort.

**Optimal tractor:** With optional trailer coupling and corresponding EC tractor approval

**7-inch LCD display:** The optional 7" display contains various displays, setting options and assistance systems

**Smart Attach:** Hydraulic attachments can be changed quickly, simply, and safely as a result of the series' installed full-hydraulic quickhitch plate

**Fuel savings:** The correct selection of the four driving modes (Power, Eco, Road, CSD) can save up to 10% fuel

**Smart Steering:** Adjust the required turns of the steering wheel individually: achieve more steering angle with fewer steering movements

## Technical Data

### Standard engine data

Engine manufacturer	Deutz
Drive output	55.4 kW
Drive output	75 PS
Cylinder capacity	2,924 cm <sup>3</sup>
Exhaust standard level	V
Exhaust aftertreatment	DOC / DPF

### Weights

Bucket capacity (standard bucket)	0.95 m <sup>3</sup>
Payload (max.)	1,710 kg
Operating weight	5,000 - 5,600 kg
Payload (S=1.25)	2,300 kg
Tipping load (standard bucket)	3,890 kg
Tipping load (pallet fork)	2,870 kg

### Filling levels

Tank capacity for fuel	85 l
Tank capacity for hydraulic oil	50 l

### Drive system

Travel speed Standard	0-20 km/h
Travel speed Option 1	0-30 km/h
Travel speed Option 2	0-40 km/h
Differential lock	100 % front axle + rear axle

### Hydraulic system

Work hydraulics discharge volume (max.)	70 l/min
-----------------------------------------	----------

### Kinematics

Kinematics type	P
Quick change system	Kramer HV/WL-C; includes Smart Attach

### Steering

Steering angle max.	40 degree
---------------------	-----------

### Noise characteristic values

Guaranteed sound power level L <sub>WA</sub> (cabin)	101 dB(A)
Measured sound power level L <sub>WA</sub>	99.4 dB(A)
Sound pressure level at the operator's ear	74 dB(A)

## Dimensions

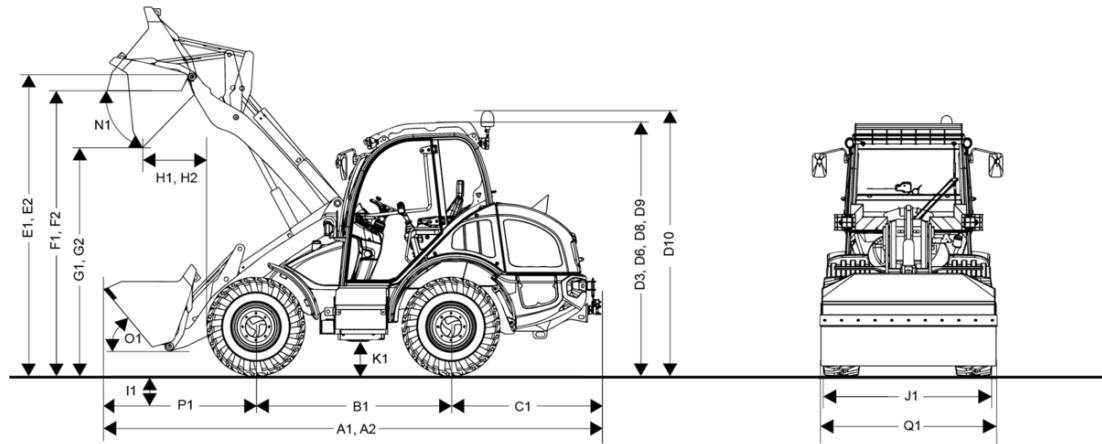

A2	extended loading system	5,665 mm
A1	Total length with standard attachment	5,359 mm
B1	Wheel base center	2,020 mm
C1	Rear overhang	1,490 mm
D3	Height with cab	2,490 mm
D6	Height with air-conditioning system	2,575 mm
D10	Total height with rotating beacon	2,765 mm
E1	Max. height blade pivot point	3,350 mm
E2	Max. height of hinge pin height extended loading system	3,500 mm
F1	Load-over height	3,200 mm
F2	extended loading system	3,350 mm
G1	Dumping height	2,680 mm
G2	extended loading system	2,810 mm
H1	Dumping width	540 mm
H2	extended loading system	730 mm
I1	Digging depth	45 mm
J1	Total width	1,780 mm
K1	Ground clearance	330 mm
L1	Turning radius outer edge wheels	2,840 mm
M1	Steering angle	40 °
M2	Swing angle	22 °
N1	Dumping angle at max. lifting height	41 °
O1	Dumping angle at ground level	50 °
P1	Distance center front axle to tooth tip	1,860 mm
Q1	Bucket width	2,050 mm
R1	Stacking height	3,130 mm
R2	extended loading system	3,280 mm
D8	Height with panoramic cab	2,530 mm
D9	Height with panoramic cab and air-conditioning system	2,575 mm

## Standard components

### Cab

- Soundproofed, vibration-insulated, 4-point cab with large, thermal insulation glazing deep-drawn and rear window heating
- Entry and exit on both sides
- Comfort seat with mechanical suspension (MSG85/722), with automatic seat belt, weight, backrest and two-fold horizontal adjustment
- 3-stage powerful heating and ventilation, and defroster nozzles on the front windscreen
- Colour-coded rocker switch for hydraulic, electric, driving and safety features
- Telescoping and adjustable tilting steering column
- Joystick console (fold-down)
- Sun visor, interior mirror, 12 V plug receptacle, cab light, large, foldable outside rear-view mirror on both sides
- Windscreen wipers front and back, front with intermittent wipers
- Working lights 2x LED basic rear, working lights 2x LED basic front (1000 Lm)
- StVZO (German road traffic regulations) lighting
- Tested according to ROPS and FOPS I

### Engine

- Battery isolator switch
- Visko fan
- Engine automatic stop

### Power transmission

- Combined brake-inch pedal
- Connectible 100% lock differential in front axle
- Mechanical parking brake
- Lubrication line for pendulum pins

### Steering and work hydraulics

- Hydrostatic all-wheel steering with emergency steering properties
- Electronic pilot-operated joystick for lifting / lowering and filling / emptying the loader unit with rocker switch for selecting the travel direction as well as integrated 3rd control circuit (proportional control) and functional lighting integrated into the joystick
- Pressure release of 3rd control circuit

### Kinematics

- Smart Attach (fully-hydraulic quickhitch facility)
- Parallel kinematics
- Load hook on the tilt rod
- Visual position display for bucket and fork

### Documentation

- Operator's manual, service manual

## Options

### Operator's cab & Cabine

- Cab with sliding window in left-side door glass
- Panoramic cab
- Air-sprung operator's seat with lumbar support and heated seat (MSG95AL/722)
- Auxiliary heating
- Outside rear-view mirrors right + left heated
- Air-conditioning system
  - only in combination with:
    - Panoramic cab
- Document box
- Radio DAB+ ready (aerial, speaker)
- Radio system DAB+ reception (BT radio, antenna, speaker)
- 7" display + jog dial (incl. angle display, oil volume adjustment, automatic load stabilizer setting, tractive force regulation, joystick sensitivity)
- Bracket for cell phone + USB outlet
- Rear-view camera
  - only in combination with:
    - 7" display + jog dial (incl. angle display, oil volume adjustment, automatic load stabilizer setting, tractive force regulation, joystick sensitivity)

## Lighting

- LED rotating beacon
- 4x LED Basic work lights at the front (1000 Lumen)
- 2x LED Basic work lights side-mounted (1000 Lumen)

## Approval, road traffic

- License plate bracket (incl. license plate illumination)
  - includes:
    - License plate illumination
    - License plate bracket, front and rear
- Sidelights for special buckets incl. side marker lights
- Data confirmation (ABE) for self-propelled work machine (standard)\*
- EC Tractor CoC for Agricultural/Forestry Tractor Approval (LOF-ZGM-EG-Zulassung, 2003/37/EC – Class T1) no data confirmation
  - only in combination with:
    - License plate bracket (incl. license plate illumination)
    - Rear outlet 7-pole
    - An attachment coupling (not maneuvering hitch) must also be selected!
- EC Tractor CoC for Agricultural/Forestry Tractor Approval (LOF-ZGM-EG-Zulassung, 2003/37/EC – Class T1) + data confirmation – only for Germany
  - only in combination with:
    - License plate bracket (incl. license plate illumination)
    - Rear outlet 7-pole
    - An attachment coupling (not maneuvering hitch) must also be selected!

\*Germany, Luxembourg, Netherlands, Austria, Slovakia, the Czech Republic, Switzerland, Estonia, Latvia, Lithuania, Hungary

## Drive system & steering

- Automatic engine stop (standard)
- 100% Limited-slip differential switchable in the rear axle
- Ecospeed 40 km/h incl. Smart Driving
  - only in combination with:
    - License plate bracket (incl. license plate light)
    - Load stabilizer (vibration damper)
- Ecospeed 40 km/h incl. Smart Driving (throttled to 20 km/h)
  - only in combination with:
    - License plate bracket (incl. license plate light)
    - Load stabilizer (vibration damper)
- Hydrostatic 30km/h
  - only in combination with:
    - Load stabilizer (vibration damper)
    - License plate bracket (incl. license plate light)
- Driving mode Power-/Eco-/ Road-/ Pedal mode (incl. slow speed device and hand throttle)
- Steering mode Smart Steering
  - only in combination with:
    - 7" inch display + Jog Dial (incl. angle display, oil volume adjustment, setting of automatic load stabilizer, tractive force regulation, sensitivity of joystick)

## Tires

Not possible with EC Tractor CoC for Agricultural/Forestry Tractor Approval (LOF-ZGM-EG-Zulassung, 2003/37/EC – Class T1)

- Mitas 340/80-20 (12.5-20) MPT-04 (standard)

## Tires for EC tractor

Required for EC Tractor CoC for Agricultural/Forestry Tractor Approval (LOF-ZGM-EG-Zulassung, 2003/37/EC – Class T1)

- Firestone 405/70R18 Duraforce – multi-purpose profile
- Michelin 400/70 R18 BIBLOAD (restricted steering angle: 38°) – multi-purpose profile
- Alliance 380/75 R20 580 ETO – traction profile
- Michelin 400/70 R 18 XMCL ETO
- Nokian 360/80R20 TRI 2 – municipal profile (caution: no digging depth / reduced steering angle)
- Trelleborg 340/80R18 TH500 ETO

## Loading system & Quick coupler system

- Load stabilizer (vibration damper)
- Loading system with increased lift height (payload and bucket volume reduced)
- Floating position
- Smart Attach (fully hydraulic quick coupler system); Kramer System HV/WL-C (standard)
- Hydraulic quick coupler system, EURO System (technical data and available attachments may differ)

The illustrations, equipment and data shown may deviate from the current delivery program of your country. Optional equipment subject to additional charge may be shown. Subject to changes.

## Hydraulics

- Pre-heating package
  - includes:
    - Hydraulic oil pre-heating (230 V)
    - Coolant pre-heating (230V)
    - Fuel pre-heating (230 V)
- Filling of the hydraulic system with environmentally friendly and biodegradable hydraulic oil

## Hydraulics - front area

- Front return line, unpressurized return + leak oil
- High flow; incl. 1 double-acting control circuit for positioning movements with attachment, incl. leak oil line and unpressurized return
  - Recommended:
    - Front outlet 7-pole (2 switch positions)
    - Driving mode Power/Eco/Road/Pedal mode (incl. low-speed control & manual throttle)
- Automatic bucket return
  - only in combination with:
    - 7" display + jog dial (incl. angle display, oil volume adjustment, automatic load stabilizer setting, tractive force regulation, joystick sensitivity)
- Shake function (vibratory function of the tipping cylinder)
  - only in combination with:
    - Automatic bucket return
    - 7" display + jog dial (incl. angle display, oil volume adjustment, automatic load stabilizer setting, tractive force regulation, joystick sensitivity)
- 4th control circuit for front add-on equipment with 2nd hydraulic function, proportional
- Tipping cylinder and lowering throttle for work platform preparation (only ex-factory, not retrofittable)
  - only in combination with:
    - Hose burst valve for lifting and tilting cylinders

## Hydraulics - rear area

- Auxiliary control circuit for tipper (tipper connection)
- Auxiliary control circuit for tipper (for rear attachments, single-acting) including unpressurized return

## Electrical system

- Rear outlet 7-pole
- Rear outlet 13-pole
- Front outlet 7-pole (2 switch positions)
- Rear outlet (DIN signal socket)
- Front outlet (30A)

## Safety options

- Hose burst valve for lifting and tilting cylinders
- Reverse alarm (acoustic)
- Red/white warning stripes (in accordance with DIN 30710)
- EquipCare + Dual ID
  - not with:
    - Immobilizer system, integrated in the ignition switch key
- Immobilizer system, integrated in the ignition switch key
  - not with:
    - EquipCare + Dual ID
- Fire extinguisher (2 kg)
- Seatbelt monitoring with seatbelt alarm
- Orange safety belt (standard)
  - not with:
    - Air-sprung operator's seat with lumbar support and heated seat (MSG95AL/722)

## Paint

- Single-color RAL custom paint finish (gray parts not included)\*\*
- Vehicle operation with corrosive agents (salt and fertilizer use)

\*\* We reserve the right to decline paint finishes that exhibit similarities to protected colors or color combinations of other manufacturers!

## Other

- (Fully automatic) central lubrication unit
  - not with:
    - Vehicle operation with corrosive agents (salt and fertilizer use)
- Central lubrication system (corrosive agents)
  - recommended with:
    - Vehicle operation with corrosive agents (salt and fertilizer use)
- Central lubrication point

## Ball hitches & Brake systems

- Ball hitch attachment coupling (K50) – fixed to frame
- Automatic attachment coupling 38 mm – fixed to frame
- Mechanical attachment coupling 32 mm – fixed to frame
- Bearing block for attachment couplings height-adjustable (insert for attachment coupling required)
- Automatic 38 mm attachment coupling insert for trailer mount height-adjustable
- K50 ball hitch insert for trailer mount height-adjustable, only suitable for height-adjustable drawbars
- K50 ball hitch insert for trailer mount height-adjustable extended
- Mechanical attachment coupling insert – 32 mm for trailer mount height-adjustable
- Hydraulic trailer brake valve
  - only in combination with:
    - Ecospeed 40 km/h incl. Smart Driving
  - or:
    - Ecospeed 40 km/h incl. Smart Driving (limited to 20 km/h)

A front ballast weight is required to operate a trailer with the corresponding bearing load!

## Extended warranties

- Security 24 (2000 h)
- Security 36 (3000 h)
- Security 48 (4000 h)
- Security 60 (5000 h)