



## WL28e

### Wheel Loader

Electric, powerful, environmentally-friendly

The power ratings of the electrically-driven WL28e wheel loader correspond to those of a conventional diesel-operated machine. The installed 96-Volt lithium-ion battery is available in three power ratings so that the running and charging times can be optimally coordinated with the work requirements. Different charging cables and plugs ensure the machine's flexible charging options. The WL28e works on-site completely free from exhaust gases and with significantly lower noise emissions. For the end user, this means greater flexibility in application, environmental protection and significant savings with operating costs. The low design of the front end therefore provides the perfect visibility and high tipping loads. It will master pallets with paving stones or other transported goods up to 1.6 t effortlessly.

### Highlights

- Powerful lithium-ion battery
- Easy charging options
- High productivity thanks to the low front carriage
- Comfort cab
- Easy-to-read digital display

### Technical Data

#### ■ Standard battery

Battery technology	Lithium-ion
Battery voltage class	96 V
Battery capacity	14.1 kWh
Battery weight	153 kg
On-board charging capacity (max.)	3 kW
Loading time (0-100%)	4,7 - 6* h
Loading time (20-80%)	2,9* h
Running time up to	2,5** h

#### ■ Battery Option 1

Battery technology	Lithium-ion
Battery voltage class	96 V
Battery capacity	18.0 kWh
Battery weight	186 kg
On-board charging capacity (max.)	6 kW
Loading time (0-100%)	3,2 - 7,5* h
Loading time (20-80%)	1,8* h
Running time up to	3,5** h

#### ■ Battery Option 2

Battery technology	Lithium-ion
Battery voltage class	96 V
Battery capacity	28.0 kWh
Battery weight	244 kg
On-board charging capacity (max.)	6 kW
Loading time (0-100%)	5,5 - 11,5* h
Loading time (20-80%)	2,7* h
Running time up to	5,3** h

#### ■ Electric motor

Motor traction drive (ECE R085)	33,1 kW
Motor work hydraulics (ECE R085)	21.2 kW

#### ■ Electrical system

Operating voltage	12 V
-------------------	------

#### ■ Weights

Bucket capacity (standard bucket)	0.42 m <sup>3</sup>
Operating weight	2,800 - 3,300 kg
Tipping load with bucket – machine straight, loading frame horizontal	1,860 - 2,510 kg
Tipping load with bucket – machine pivoted, loading frame horizontal	1,560 - 2,070 kg

Tipping load with pallet fork – machine straight, loading frame horizontal	1,550 - 2,070 kg
Tipping load with pallet fork – machine pivoted, loading frame horizontal	1,310 - 1,720 kg

#### ■ Driver's cab

Driver's cab	FSD (EPS, cabin)
--------------	------------------

#### ■ Filling levels

Tank capacity for hydraulic oil	30 l
---------------------------------	------

#### ■ Drive system

Type of drive	Electrical
drive unit	universal joint shaft
Speed levels	2
Axle	PA940
Travel speed Standard	0-15 km/h
Travel speed Option 1	0-20 km/h
Travel speed Option 2	0-25 km/h
Operating brake	Multi-disc brake on front axle acting on rear axle via universal joint shaft
Parking brake	Electric parking brake with hill-hold function
Differential lock	100 % front axle + rear axle(option)

#### ■ Hydraulic system

Work hydraulics discharge volume (max.)	44 l/min
Work hydraulics working pressure (max.)	210 bar

#### ■ Kinematics

Kinematics type	P
-----------------	---

Lifting cylinder	2
------------------	---

Tipping cylinder	1
------------------	---

Quick change system	hydraulic
---------------------	-----------

#### ■ Steering

Steering type	hydraulically activated articulated pendulum steering
---------------	---

Steering cylinder	1
-------------------	---

Oscillating angle	± 8 degree
-------------------	------------

#### ■ Noise characteristic values

Average sound power level LwA (operator's canopy)	83.9 dB(A)
---	------------

Guaranteed sound power level LwA (operator's canopy)	85 dB(A)
--	----------

Specified sound pressure level LpA (operator's canopy)	60 dB(A)
--	----------

Average sound power level LwA (cabin)	83.9 dB(A)
---------------------------------------	------------

Guaranteed sound power level LwA (cabin)	85 dB(A)
--	----------

Specified sound pressure level LpA (cabin)	64 dB(A)
--	----------

#### ■ Other information

FSD = overhead guard  
 EPS = Easy Protection System (fold-down overhead guard)  
 Tipping load calculation pursuant to ISO 14397  
 \*The charging time is dependent on different charging options. Onboard charger 3 kW (standard) with auxiliary onboard charger, overall 6 kW (option). The following charging plugs are available: 230 V / 10 A Schuko, 230 V / 16 A CEE (blue, 3-pole), 400 V / 16 A CEE (red, three-phase current, 5-pole), 400 V / 16 A (type 2 Wallbox plug, IEC 62196) and other adapter plugs.  
 \*\*The battery charging times are dependent on the respective application conditions, the task being performed and the driving style. This can result in a longer running time. However, in extreme cases, it is also possible that you may fall short of the specified running times. The specified running times refer to uninterrupted operation and working with the machine.

## Dimensions

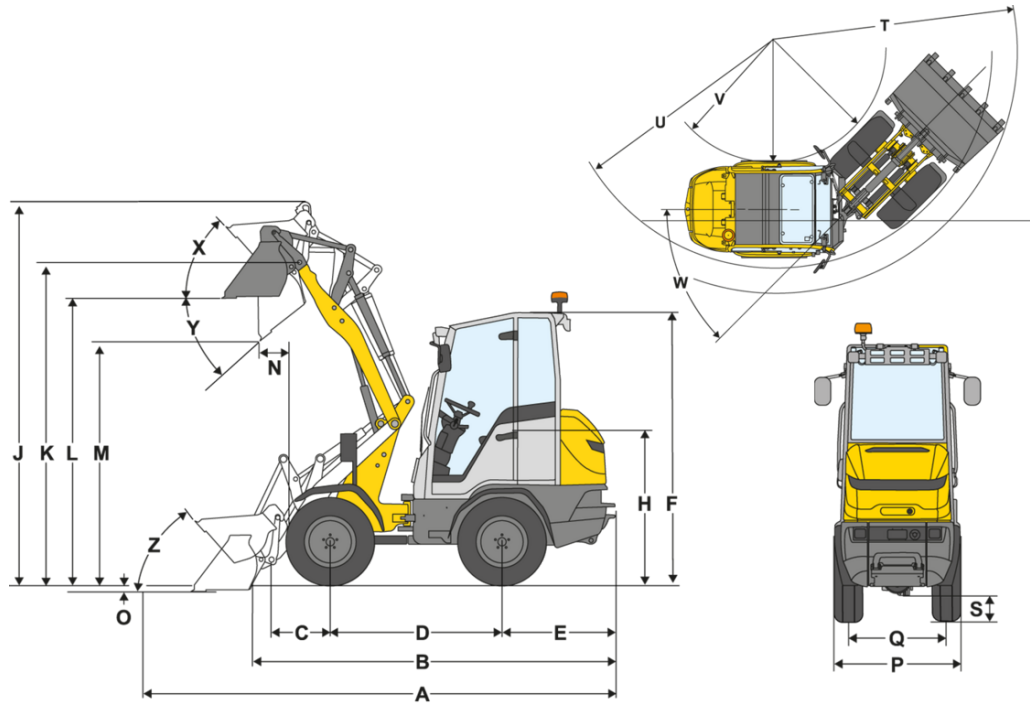

A	Total length	4,616 mm
B	Total length without bucket	3,710 mm
C	Bucket pivot point (to center of axle)	670 mm
D	Wheel base	1,760 mm
E	Rear overhang	1,230 mm
F	Height with operator's canopy (fixed)	2,340 mm
	Height with fold-down operator's canopy (EPS)	2,395 mm
F	Height with fold-down operator's canopy (EPS), folded down	1,890 mm
	Height with cab	2,350 mm
H	Seat height	1,350 mm
J	Total working height	3,210 mm
K	Bucket pivot point (max. lift height)	2,560 mm
L	Load-over height	2,240 mm
M	Dumping height	1,700 mm
N	Reach (at M)	520 mm
O	Digging depth	130 mm
P	Total width	1,250 mm
Q	Track width	940 mm
S	Ground clearance	270 mm
T	Maximum external radius	3,200 mm
U	Radius on the outer edge	2,800 mm
V	Inner radius	1,510 mm
W	Articulation angle	45 °
X	Rollback angle at max. lift height	47 °
Y	Dumping angle	41 °
Z	Rollback angle on ground	50 °