



## WL950

### Wheel Loader

#### The top performer

These features characterise the WL950 wheel loader: Comfort cabin with excellent ergonomics and 360° visibility, electronically controlled drive system with various operating modes, sturdy load arm with an optimal view of the attachment, large range of options and a modern machine design. The transversely installed engine and the optimised arrangement of components ensure very good maintenance access. The WL950 is the ideal model in the wheel loader class with 30.02 ft<sup>3</sup> bucket volume. It combines power, reliable hydraulics and compact dimensions with well-engineered technology and an excellent price-performance ratio.

### Highlights

- Comfortable Cab
- Perfectly matched Z-kinematics
- Robust central joint with optimized hose routing
- Motor installed transversely
- Service access front end

### Technical Data

#### Standard engine data

Engine manufacturer	Kohler
Motor type	KDI1903TCR
Cylinder	3
Drive output	42 kW
Drive output	56.3 HP
at max. rpm	2,600 rpm
Cylinder capacity	113.6 in <sup>3</sup>
Type of coolant	Water
Exhaust standard level	V
Exhaust aftertreatment	DOC/DPF

#### Electrical system

Operating voltage	12 V
Battery	100 Ah
Alternator	120 A

#### Weights

Bucket capacity (standard bucket)	30.02 ft <sup>3</sup>
Operating weight	11,023 - 11,464 lb
Tipping load with bucket – machine straight, loading frame horizontal	7,871 - 8,708 lb
Tipping load with bucket – machine pivoted, loading frame horizontal	6,768 - 7,518 lb

Tipping load with pallet fork – machine straight, loading frame horizontal	6,526 - 7,187 lb
--	------------------

Tipping load with pallet fork – machine pivoted, loading frame horizontal	5,644 - 6,239 lb
---	------------------

#### Driver's cab

Driver's cab	Cab
--------------	-----

#### Filling levels

Tank capacity for fuel	21.13 US gal
------------------------	--------------

Tank capacity for hydraulic oil	8.45 US gal
---------------------------------	-------------

#### Drive system

Type of drive	electronically controlled
---------------	---------------------------

drive unit	Hydrostatic via transfer gearbox and universal joint shaft
------------	--

Speed levels	2
--------------	---

Axle	PA1422
------	--------

Travel speed Standard	0-12.43 mph
-----------------------	-------------

Operating brake	Drum brake
-----------------	------------

Parking brake	drum brake (mechanical handbrake lever)
---------------	---

Differential lock	100 % front axle + rear axle
-------------------	------------------------------

### ■ Hydraulic system

Drive hydraulics working pressure (max.)	7,252 psi
Work hydraulics discharge volume (max.)	19.55 gpm
Work hydraulics working pressure (max.)	3,408 psi

### ■ Kinematics

Kinematics type	Z
Lifting cylinder	1
Tipping cylinder	1
Quick change system	hydraulic

### ■ Steering

Steering type	hydraulically activated articulated pendulum steering
Steering cylinder	1

### ■ Noise characteristic values

Average sound power level LwA (cabin)	99.9 dB(A)
Guaranteed sound power level LwA (cabin)	101 dB(A)
Specified sound pressure level LpA (cabin)	69 dB(A)

### ■ Other information

DPF = diesel particulate filter  
 DOC = diesel oxidation catalyst  
 Tipping load calculation pursuant to ISO 14397

## Dimensions

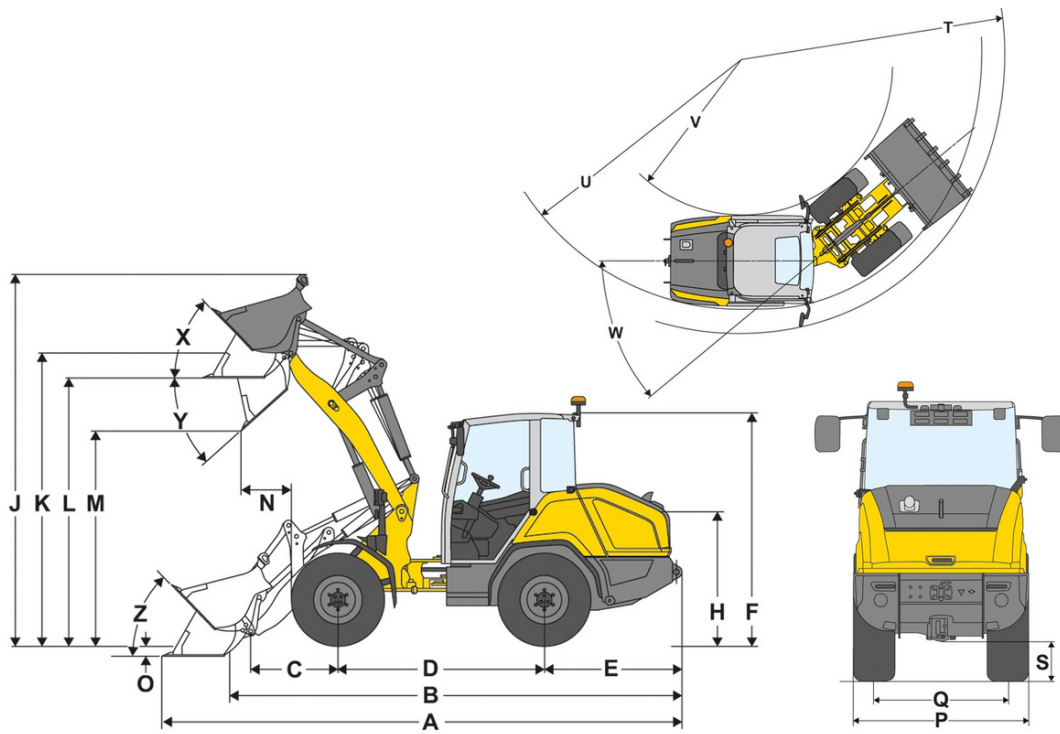

A	Total length	213.8 in
B	Total length without bucket	183.9 in
C	Bucket pivot point (to center of axle)	37.8 in
D	Wheel base	84.6 in
E	Rear overhang	56.5 in
F	Height with cab	98.8 in
H	Seat height	58.5 in
J	Total working height	160.2 in
K	Bucket pivot point (max. lift height)	128.0 in
L	Load-over height	117.9 in
M	Dumping height	96.5 in
N	Reach (at M)	26.6 in
O	Digging depth	3.3 in
P	Total width	72.0 in
Q	Track width	55.9 in
S	Ground clearance	14.8 in
T	Maximum external radius	169.3 in
U	Radius on the outer edge	154.9 in
V	Inner radius	81.5 in
W	Articulation angle	40 °
X	Rollback angle at max. lift height	66 °
Y	Dumping angle	45 °
Z	Rollback angle on ground	44 °