



WEIDEMANN
designed for work

T9535 Telehandlers

Technical data

■ Electrical system

Operating voltage	12 V
Battery	185 Ah
Alternator	150 A

■ Weights

Payload (max.)	3,500 kg
Operating weight	7,720 kg

■ Driver's cab

Driver's cab	Cab
--------------	-----

■ Filling levels

Tank capacity for fuel	142 l
Tank capacity for hydraulic oil	90 l
Tank capacity for urea solution	19 l

■ Drive system

Type of drive	Hydrostatic (electronically regulated)
drive unit	universal joint shaft
Speed levels	3
Axle	PAL 1930
Travel speed Standard	0-20 km/h
Travel speed Option 1	0-40 km/h
Operating brake	Multi-disc brake on front axle acting on rear axle via universal joint shaft
Parking brake	Electro-hydraulic multi-disc brake with spring suspension on the front axle, acting on rear axle via universal joint shaft
Differential lock	100 % front axle (option)

■ Hydraulic system

Drive hydraulics working pressure (max.)	500 bar
--	---------

Work hydraulics discharge volume (max.)	138,6 (187) l/min
Work hydraulics working pressure (max.)	261 bar

■ Kinematics

Lifting cylinder	1
Tipping cylinder	1
Quick change system	Mechanical (hydraulically activated)

■ Steering

Steering type	Hydrostatic all-wheel steering with end position synchronization
Steering cylinder	2
Steering angle max.	2x45 degree
Oscillating angle of the rear axle	± 10 degree

■ Standard engine data

Engine manufacturer	Perkins
Motor type	904J-E36TA
Cylinder	4
Drive output	100 kW
Drive output at max. rpm	136 PS
Cylinder capacity	2,200 U/min
Type of coolant	3,621 cm ³
Exhaust standard level	Water
Exhaust aftertreatment	V
Average sound power level L _{WA} (cabin)	DOC/DPF/SCR
Guaranteed sound power level L _{WA} (cabin)	105 dB(A)
Specified sound pressure level L _{pA} (cabin)	106 dB(A)
	76 dB(A)

Dimensions

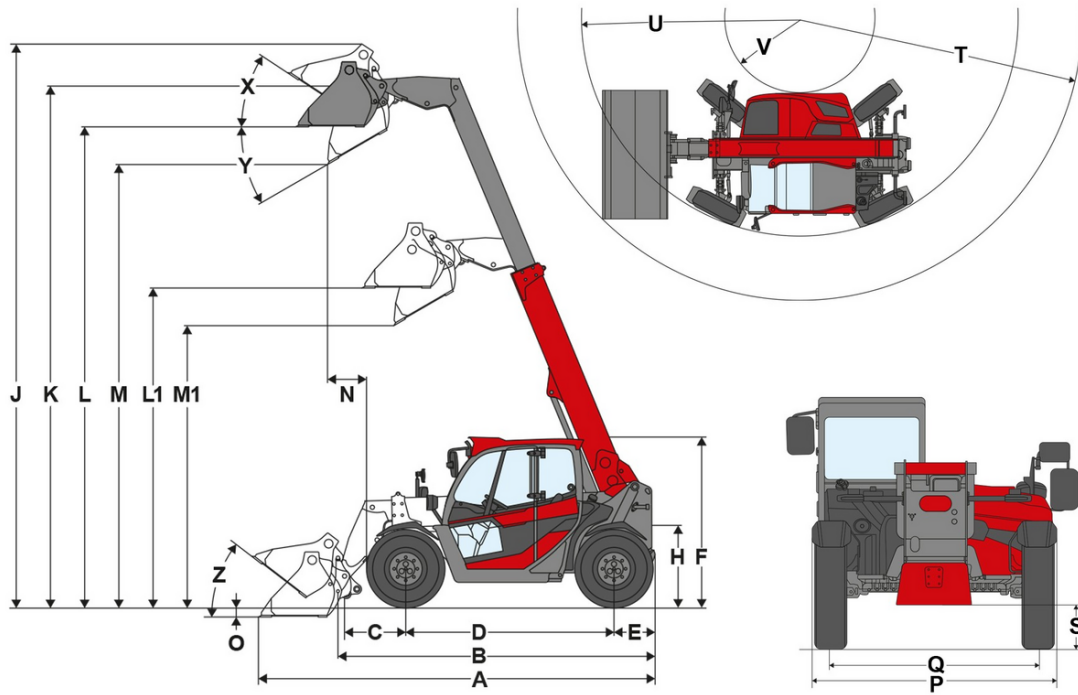

A	Total length	6,275 mm
B	Total length without bucket	5,290 mm
D	Wheel base	2,950 mm
E	Rear overhang	700 mm
F	Height with cab	2,425 mm
H	Seat height	1,370 mm
J	Total working height	10,450 mm
K	Bucket pivot point (max. lift height)	9,855 mm
L1	Load-over height telescopic arm retracted	4,650 mm
L	Load-over height telescopic arm extended	9,305 mm
M1	Dumping height telescopic arm retracted	4,135 mm
M	Dumping height telescopic arm extended	8,785 mm
O	Digging depth	185 mm
P	Total width	2,450 mm
Q	Track width	1,930 mm
S	Ground clearance	370 mm
T	Maximum radius	5,155 mm
U	Radius on the outer edge	3,700 mm
V	Inner radius	1,640 mm
X	Rollback angle at max. lift height	111 °
Y	Dumping angle	44 °
Z	Rollback angle on ground	46 °

Standard components

Engine

- Perkins 904J-E36T, 90 kW / 122 hp, stage V

Steering system

- Hydraulic all-wheel steering with end position synchronization
- Steering angle max. 2 x 45°
- Swing angle rear axle $\pm 10^\circ$
- Steering cylinder: 2

Operator's cab

- Cab with heating and ventilation ROPS / FOPS tested with VSG safety window on the right side
- Front, roof and rear wipers
- Adjustable steering column
- Spring-loaded armrest with joystick mounted on the seat
- 7" color display for all important machine information
- Cup holder
- Storage compartments

Operator's seat

- Comfort seat with safety belt

Lighting

- Lighting according to StVZO
- LED working lights: 2 front, 1 rear on the overhead guard

Drive system & Axles

- Drive: Power Drive 255, hydrostatic via transfer case and universal joint shaft, electronically controlled
- Speed: 20 km/h
- Speed levels: 2 (7 km/h / 20 km/h (optional 40)
- Operating brake: multi-disc brake in the front axle effective on the rear axle via the universal joint shaft
- Parking brake: electro-hydraulic multi-disc brake with spring mechanism in the front axle, effective on the rear axle via the universal joint shaft
- Steering types: :3 steering types, electrically adjustable

Tires

- Mitas 405/70 R24 MPT-01

Loading system

- Telescopic arm lift height 9855 mm
- Quickhitch facility (Manitou system) mechanical
- Lift cylinder: 1
- Tipping cylinder: 1

Hydraulics

- Electrically pilot controlled joystick with direction switch and telescopic function
- 3rd Control circuit; connections Flatface size 2
- vls (Vertical Lift System)

Other

- Reversing alarm (acoustic)

EquipCare (telematics)

- EquipCare 36 months (incl. App & Manager)

Options

Operator's cab & Cabine

- Windscreen wipers on right side
- Heated windshield right and rear
- Protective grate on front windshield, removable
- Electrical mirror adjustment for right side
- Fabric seat; air sprung
- Fabric seat; air sprung, heated seat
- Air-conditioning system
- Automatic climate control
- DAB+ radio-ready (aerial, speaker)
- DAB+ radio, Bluetooth / USB / AUX-in
- 2 sockets: 12V / USB
- 3 sockets: 12V / USB / 3-pole
- 3 sockets: 12V / 12 V / 3-pole
- Cellphone mount

Lighting

- 2 additional basic LED work lights, front
- 2 additional basic LED work lights, rear
- 2 basic LED work lights on the telescopic arm
- 2 additional premium LED work lights, front
- 2 additional premium LED work lights, rear
- 2 premium LED work lights on the telescopic arm
- LED rotating beacon (yellow), National regulations must be maintained!

Approval & Road traffic

- Diesel engine Perkins 100 kW / 136 hp torque 550 Nm
- Reverse fans
- Engine pre-heating (coolant) 230 V
- Engine pre-heating (coolant) + hydraulic oil pre-heating 230 V
- Radiator maintenance access

Drive system & Axles

Axles

- 100 % differential lock in front axle

Drive mode

- Auto/Eco mode drive mode

Travel speed

- Speed restrictor proportional (slow drive facility) incl. hand throttle
- 40 km/h Power Drive 255, (speed increase)

Tires

- Firestone 460/70 R24 Duraforce, profile MPT, width 2450 mm, height 2440 mm
- Michelin 460/70 R24 XMCL, profile AS, width 2450 mm, height 2440 mm
- Michelin 460/70 R24 Bibload, Bibload profile, width 2450 mm, height 2440 mm
- 460/70R24 Trelleborg TH500, MPT profile, width 2450 mm, height 2440 mm

Loading system

Quick change plates

- Hydraulic Manitou
- Mechanical Kramer
- Hydraulic Kramer
- JCB (Q-Fit) hydraulic
- Matbro hydraulic
- Without quick change plate

- Dirt wiper telescopic arm
- Lifting arm dampening & Tipping cylinder lock
- Lifting arm dampening, float position & Tipping cylinder lock

Hydraulics

- Shell PANOLIN S4 HLP Synth 46 (Biohydraulic oil)

Hydraulics in front

- Large pump (230 l/min)
- Front changeover valve on 3rd Control circuit (3rd control circuit with 4 couplings)
- Pressure release, 3rd Front control circuit on telescopic arm

Hydraulics in rear

- One rear, dual-acting hydraulic connection (two couplings) + tipper connection rear, single-acting (one coupling)

Electrical system

front

- Socket front, 13-pole, (2x electrical functions E1/ E2 and lighting), operation: Using 2 keys on the joysticks; 1st function tentative, 2nd function resting
- Socket front, 13-pole, (2x electrical functions E1/ E2 and lighting), operation: Using 2 keys on the joysticks; 1st function tentative, 2nd function resting
- Socket front, 13-pole, (2x electrical functions E1/ E2 and lighting), operation: Using 2 keys on the joysticks; 1st function tentative, 2nd function resting
- Socket front, 13-pole, (2x electrical functions E1/ E2 and lighting), operation: Using 2 keys on the joysticks; 1st function tentative, 2nd function resting

rear

- Rear socket 7-pole for lighting rear attachments

Safety options

- Immobilizer KAT, operation: via coded ignition key
- Internal panoramic mirror
- Reversing camera
- Front camera incl. additional display

Other

- Toolbox
- Central lubrication system, fully-automatic
- Service valve engine-oil change
- Center tunnel cover

Trailer and recovery equipment

- Mirror for attachment coupling
- Railway coupling (not permitted for trailer operation)
- Automatic yoke
- Auto hitch
- Bearing block for attachment coupling
- Automatic attachment coupling, height-adjustable for bearing block
- Ball hitch attachment coupling K80, height-adjustable for bearing block
- Ball hitch attachment coupling K50, height-adjustable for bearing block
- Ball hitch attachment coupling K50 long, height-adjustable for bearing block
- Piton-Fix attachment coupling, height-adjustable for bearing block
- Trailer hitch 32mm mechanical
- Trailer hitch 32mm mechanical, height-adjustable for bearing block
- Hydraulic attachment brake
- Dual-line, pressure air-brake system

Approval as tractor

- EC tractor approval (CoC) (International)
- EC tractor approval (CoC) + data confirmation for Germany