



## 5080 Wheel loaders

### Technical Data

#### ■ Standard engine data

Engine manufacturer	Perkins
Motor type	904J-E36TA
Cylinder	4
Drive output	100 kW
Drive output	136 PS
at max. rpm	2,200 U/min
Cylinder capacity	3,621 cm <sup>3</sup>
Type of coolant	Water
Exhaust standard level	V
Exhaust aftertreatment	DOC/DPF/SCR

#### ■ Electrical system

Operating voltage	12 V
Battery	135 Ah
Alternator	85 A

#### ■ Weights

Operating weight	7,000 kg
Tipping load with bucket – machine straight, loading frame horizontal	4,762 kg
Tipping load with bucket – machine pivoted, loading frame horizontal	3,926 kg
Tipping load with pallet fork – machine straight, loading frame horizontal	4,254 kg
Tipping load with pallet fork – machine pivoted, loading frame horizontal	3,559 kg

#### ■ Driver's cab

Driver's cab	Cab
--------------	-----

#### ■ Filling levels

Tank capacity for fuel	105 l
Tank capacity for hydraulic oil	95 l
Tank capacity for urea solution	19 l

#### ■ Drive system

Type of drive	Hydrostatic
---------------	-------------

drive unit	universal joint shaft
Speed levels	2
Axle	PA 1422/2
Travel speed Standard	0-20 km/h
Travel speed Option 1	0-30 km/h
Travel speed Option 2	0-40 km/h
Operating brake	Disc brake (combined with parking brake)
Parking brake	Service and parking brake in the drive train acts on all 4 wheels
Differential lock	100 % front axle + rear axle

#### ■ Hydraulic system

Drive hydraulics working pressure (max.)	455 bar
Work hydraulics discharge volume (max.)	100 (115-150) l/min
Work hydraulics working pressure (max.)	210 bar

#### ■ Kinematics

Kinematics type	Z
Lifting cylinder	2
Tipping cylinder	1
Quick change system	hydraulic

#### ■ Steering

Steering type	hydraulically activated articulated pendulum steering
Steering cylinder	2
Oscillating angle	±12 degree

#### ■ Noise characteristic values

Average sound power level L <sub>wA</sub> (cabin)	101.4 dB(A)
Guaranteed sound power level L <sub>wA</sub> (cabin)	103 dB(A)
Specified sound pressure level L <sub>pA</sub> (cabin)	74 dB(A)

#### ■ Other information

FSD = operator's canopy  
DPF = diesel particulate filter  
DOC = diesel oxidation catalyst  
SCR = selective catalytic reduction  
Tipping load calculation pursuant to ISO 14397

## Dimensions

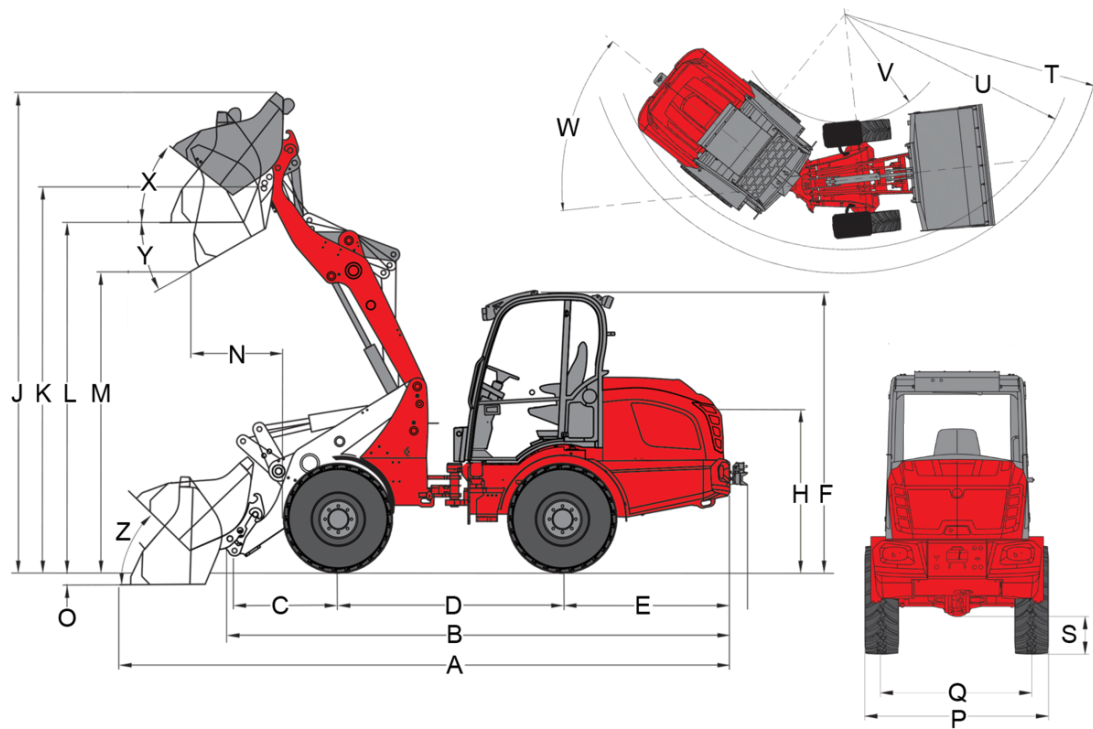

### Z-kinematics (standard)

	Standard components	550/45-22.5 AS ET0
<b>A</b>	Total length	5,800 mm
<b>B</b>	Total length without bucket	4,790 mm
<b>C</b>	Bucket pivot point (to center of axle)	990 mm
<b>D</b>	Wheel base	2,150 mm
<b>E</b>	Rear overhang	1,580 mm
<b>F</b>	Height with operator's canopy (fixed)	
	Height with fold-down operator's canopy (EPS)	
	Height with fold-down operator's canopy (EPS), folded down	
	Height with lowerable operator's canopy (EPS Plus), lowered	
	Height with lowerable operator's canopy (EPS Plus)	
	Height with lowered operator's canopy	
	Height with operator's canopy raised	
	Height with cab lowered	
	Height with cab raised	
	Height with cab	2,690 mm
<b>H</b>	Seat height	1,570 mm
<b>J</b>	Total working height	4,580 mm
<b>K</b>	Bucket pivot point (max. lift height)	3,690 mm
<b>L</b>	Load-over height	3,350 mm
<b>M</b>	Dumping height	2,880 mm
<b>N</b>	Reach (at M)	850 mm
<b>O</b>	Digging depth	100 mm
<b>P</b>	Total width	1,984 mm
<b>Q</b>	Track width	1,449 mm
<b>S</b>	Ground clearance	375 mm
<b>T</b>	Maximum external radius	4,135 mm
<b>U</b>	Radius on the outer edge	3,683 mm
<b>V</b>	Inner radius	1,599 mm
<b>W</b>	Articulation angle	45 °
<b>X</b>	Rollback angle at max. lift height	38 °
<b>Y</b>	Dumping angle	28 °
<b>Z</b>	Rollback angle on ground	46 °

The illustrations, equipment and data shown may deviate from the current delivery program of your country. Optional equipment subject to additional charge may be shown. Subject to changes.

## Standard components

### Engine

- Perkins 904J-E36TA, 100 kW / 136 hp, stage V

### Tires

- 550/45-22.5 AS ET0, profile AS, width 1990 mm (incl. front water filling)

### Steering system

- Hydraulic articulated pendulum steering, pendulum angle  $\pm 12^\circ$
- Steering cylinder: 2

### Drive system & Axles

- Axle PA1422/2
- Hydrostatic all-wheel drive, driving direction selectable via joystick
- Service brake: Disc brake (combined with parking brake)
- Central service and parking brake in drive train acting on all 4 wheels
- Differential lock 100% electric-hydraulic engageable on front and rear axles

### Hydraulics

- 3rd Front control circuit electrically proportional parallel via joystick, incl. double detent; hydraulic oil cooler
- Float position for lifting cylinder
- Oil quantity adjustment via jog dial
- Pressure relief of hydraulic connections on loading swing arm

### Operator's cab

- Comfort cab with heating and ventilation, laterally tiltable, ROPS / FOPS tested
- Comfort seat with seat belt full suspension, weight, back and longitudinal adjustment
- Adjustable steering wheel (inclination)
- Right armrest
- Hydraulically pre-controlled joystick with direction switch and integrated push button for differential lock
- Worklights 2 front and 2 rear
- Operating hours meter
- Fuel gauge

### Other

- Lighting system according to StVZO
- Bucket level indicator
- Self-recovery coupling

### Loading system

- Weidemann hydraulic

### EquipCare (telematics)

- EquipCare 36 months (incl. App & Manager)

### Operator's seat

<ul><li>Weidemann hydraulic</li></ul>

### Lighting

<ul><li>EquipCare 36 months (incl. App & Manager)</li></ul>

## Options

### Operator's cab

- Front window protective grating
- Storage box with bottle holder (left next to the operator's seat)
- Radio DAB+-ready (aerial, speaker)
- Radio DAB+ complete
- Air-conditioning system (height +25 mm)
- Cabin outlet 230 V (connection power max. 2000 W), (Only works with connected engine pre-heating on the 230 V grid)

### Operator's seat

- Fabric seat; heated seats (MSG 85)
- Fabric seat; air suspension (MSG 95AL/722)
- Fabric seat; air suspension; heated seats (MSG 95AL/732)

### Lighting

- LED working lights, 2 front 2 rear
- Rotating beacon (yellow), The national (regulations must be observed!)

### StVZO – equipment

- Individual operating permit > 25 km/h
- Individual operating permit > 25 km/h
- Registration plate mounting

### Engine

- Manual throttle
- Engine pre-heating (coolant) + hydraulic oil pre-heating 230 V

### Drive system & Axles

- 30 km/h (speed increase)
- 40 km/h (speed increase)
- Manual inching (slow speed device)
- Front mud flaps (mounted on the fender)

### Tires

- 400/70-20 AS ET0 AS504, tread AS, width 1840 mm
- 400/70-20 AS ET-50 AS504, tread AS, width 1930 mm
- 500/45-20 AS ET0, tread AS, width 1920 mm
- 550/45-22.5 AS ET-50, tread AS, width 2080 mm
- 600/40-22.5 AS ET-50, tread AS, width 2120 mm
- 405/70 R 18 EM Alliance 608 ET0, tread EM, width 1815 mm
- 405/70 R 20 EM Alliance 608 ET0, tread EM, width 1829 mm
- 340/80 R 18 ET0 Alliance Multiuse 550, tread Multiuse, width 1770 mm
- 400/70 R 20 ET0 Alliance Multiuse 550, tread Multiuse, width 1830 mm
- 400/70 R 20 ET-60 Alliance Multiuse 550, tread Multiuse, width 1950 mm
- 400/70 R 20 ET-50 Michelin Bibload, tread Bibload, width 1944 mm

### Loading system

- Loading swing arm damping
- Lowering brake valve (hose burst valves for lift and tipping cylinders)

### Quick change plates

- Euro hydraulic
- SkidSteer hydraulic
- SMS hydraulic
- Kramer hydraulic
- Volvo TPV hydraulic

### Hydraulics in front

- Front pressureless return (incl. leakage oil line)
- 3rd Control circuit flow sharing 100 l/min (loading swing arm can be operated together with 3rd Control circuit)
- 3rd Control circuit flow sharing 115 l/min (loading swing arm can be operated together with 3rd Control circuit)
- 4th Control circuit flow sharing 100 l/min (loading swing arm can be operated together with 3rd Control circuit)
- 4th Control circuit flow sharing 115 l/min (loading swing arm can be operated simultaneously)
- High Flow Load-Sensing - power hydraulics double-acting 150 l/min (machine height +30 mm!)
- 3rd Control circuit electrical proportional serial (loading swing arm can be operated together with 3rd Control circuit)
- 4th Control circuit additionally electrically proportional parallel (operation: Via control wheel on right side of joystick)
- Additional hydraulic oil cooler

### Hydraulics in rear

- Pressureless return in rear
- One hydraulic connection rear double-acting via changeover valve (l/min like 3rd Control circuit front), (3rd Control circuit front or rear), (Operation: Via switch (0 - 1) in joystick console + 3rd control circuit)
- One rear hydraulic connection (63 l/min) double-acting (two couplings) incl. separate control valve (Operation: Via switch (1 - 0 - 2) in joystick console)
- Two rear hydraulic connections (63 l/min) double-acting (four couplings) incl. separate control valve (operation: 1 DW connection via switch (1 - 0 - 2), 1 DW connection via pushbutton (1 - 0 - 2)), (connections can be operated simultaneously)

The illustrations, equipment and data shown may deviate from the current delivery program of your country. Optional equipment subject to additional charge may be shown. Subject to changes.

### **Bio-hydraulic oil**

- Shell PANOLIN S4 HLP Synth 46 (Bio-hydraulic oil)

### **Electrical connections in front**

- Front socket 7-pin for lighting front attachments
- Front socket 3-pin for double function (operation: Via 2 buttons on the joystick; 1st Function push-button, 2nd Function latching)
- Front socket 3-pin for double function (operation: Via 2 buttons on the joystick; 1st Function latching, 2nd Function push-button)
- Front socket 3-pin for double function (operation: Via 2 buttons on the joystick; 1st Function push-button, 2nd Function push-button)
- Front socket 3-pin for double function (operation: Via 2 buttons on the joystick; 1st Function latching, 2nd Function latching)

### **Electrical connections in rear**

- Rear 7-pin socket for lighting rear attachments
- Rear 3-pin socket (operation: Via switch (1 - 0 - 2) in joystick console)

### **Safety options**

- Reversing warning device (acoustic)
- Immobilizer (operation via coded ignition key)
- Lockable DEF tank cap

### **Other**

- Battery disconnect switch 2 circuits (disconnection of the on-board power supply and the generator via 2 switching paths from the battery)
- Hand lever grease press
- Combination bag (warning triangle / first aid kit)
- Tool box
- Set of tools
- Drive shaft protection
- Fully automatic central lubrication unit

### **Warranty extension**

- Economy 24 months (2500 h)
- Economy 36 months (3000 h)
- Economy 48 months (3500 h)
- Economy 60 months (4000 h)
- Premium 24 months (3000 h)
- Premium 36 months (4000 h)
- Premium 48 months (5000 h)
- Premium 60 months (6000 h)

### **Custom-made paint finish**

- Special painting RAL single color - instead of Weidemann red
- Special painting RAL multicolored

### **Trailer and recovery equipment**

- Trailer hitch automatic
- Trailer hitch height adjustable, automatic
- Trailer hitch height adjustable, ball head
- Trailer Hitch

### **Self-propelled work machines with ball hitch**

- Trailer hitch automatic