



EZ26e

Tracked Zero Tail Excavator

Energetic powerhouse, electrify your everyday working life.

The EZ26e redefines the future of excavator operation. It offers maximum performance, comfort and environmental friendliness. Its impressive design and innovative technology enable it to excel in the most demanding applications. From landscaping to interior demolition, from urban environments to noise-sensitive areas - the EZ26e is a versatile powerhouse. The EZ26e is not just an excavator, but a solution for the future of construction. Its emission-free, quiet and low-vibration operation makes it the ideal choice for legally restricted areas, noise-sensitive and environmentally sensitive areas as well as for niche areas where there are local and time restrictions.

Highlights

- Emission-free and quiet operation
- Flexible charging options and long runtimes
- Unsurpassed performance
- Zero Tail
- High comfort and safety standards

Technical Data

Hydraulic

Operating pressure hydraulics	240.0 bar
Hydraulic pump	Axial piston pump
Flow rate max.	68.6 l/min

Mechanical - Output Details

Travel speed stage 1	2.8 km/h
Travel speed stage 2	4.9 km/h

Mechanical Details

Length	4,604.0 mm
Width	1,500.0 mm
Height	2,524.0 mm
Operating weight (min.-max.)	2,440.0 - 3,024.0 kg

Digging depth (max.)	2,803.0 mm
----------------------	------------

Motor

Nominal power	11.70 kW
Nominal current	350.0 A
Nominal voltage	96.0 V
Nominal speed	2,450.0 1/min

Environment Data

Sound power LWA, guaranteed	85.0 dB(A)
-----------------------------	------------

Electrical System

Type of battery	Li-Ion
-----------------	--------

Shipping and Storage

Shipping weight	2,315.0 - 2,900.0 kg
-----------------	----------------------

Dimensions

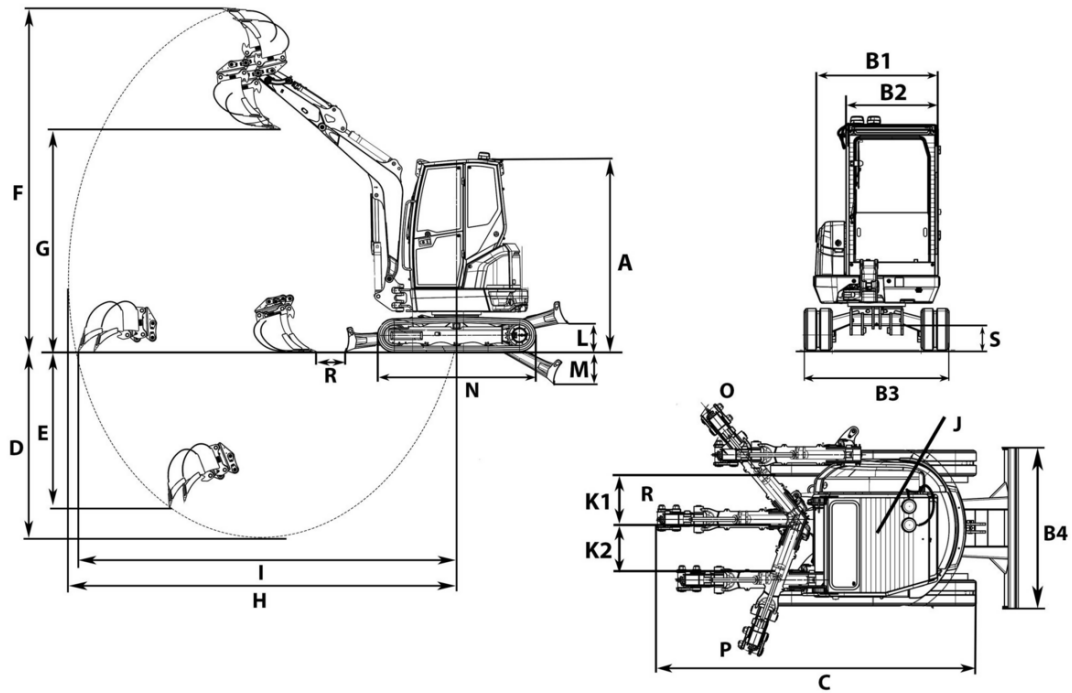

A	Height	2,412 mm	2,434 mm
B1	Width of upper carriage	1,350 mm	1,350 mm
B2	Width of cab	980 mm	980 mm
B3	Width travel gear	1,500 mm	1,550 mm
C	Transport length short shovel arm	4,199 mm	4,199 mm
C	Transport length long shovel arm	4,212 mm	4,212 mm
D	Digging depth max., short shovel arm	2,603 mm	2,603 mm
E	Piercing depth max., short shovel arm	1,124 mm	1,124 mm
F	Piercing height max., short shovel arm	4,151 mm	4,151 mm
F	Piercing height max., long shovel arm	4,280 mm	4,280 mm
G	Dumping height max., short shovel arm	2,764 mm	2,764 mm
G	Dumping height max., long shovel arm	2,893 mm	2,893 mm
H	Digging radius max., short shovel arm	4,622 mm	4,622 mm
H	Digging radius max., long shovel arm	4,813 mm	4,813 mm
I	Max. reach at ground level (short shovel arm)	4,508 mm	4,508 mm
I	Max. reach at ground level (long shovel arm)	4,706 mm	4,706 mm
J	Tail swing radius	859 mm	859 mm
K1	Boom offset max. (to center of bucket right side)	622 mm	622 mm
K2	Boom offset max. (to center of bucket left side)	584 mm	584 mm
L	Stacking height max. (dozer blade above surface)	352 mm	374 mm
M	Digging depth max. (dozer blade below surface)	409 mm	387 mm
N	Length travel drive	1,982 mm	2,037 mm
O	Boom swing radius right	1,982 mm	1,982 mm
P	Boom swing radius left	1,729 mm	1,729 mm
R	Distance bucket dozer blade, short shovel arm	437 mm	437 mm
R	Distance bucket dozer blade, long shovel arm	351 mm	351 mm
S	Ground clearance	263 mm	285 mm