



## EZ25

### Tracked Zero Tail Excavator

#### Comfort and Power.

The EZ25 compact excavator offers a modern design, flexibility, and operator-friendliness. Taking the car trailer to the next construction site? No problem – the low weight allows transport including an attachment with a 3.5 metric ton trailer. The EZ25 offers an ergonomic workplace with joystick mount, a wide cab entry, and well-placed operating and display elements.

## Highlights

- Up to four additional factory-installed control circuits
- Zero Tail
- Canopy can be easily disassembled
- Optimized hydraulics or engine-pump management
- Easy transportation by car trailer

## Technical Data

### Hydraulic

Operating pressure hydraulics	225.0 bar
Flow rate max.	90.0 l/min
Tank capacity	30.0 l

### Mechanical - Output Details

Nominal rotation speed	2,500.0 1/min
Travel speed stage 1	2.1 km/h
Travel speed stage 2	3.8 km/h

### Mechanical Details

Length	4,290.0 mm
Width	1,570.0 mm
Height	2,414.0 mm
Operating weight (min.-max.)	2,656.0 - 3,513.0 kg
Digging depth (max.)	2,737.0 mm

### Engine

Cooling	Water-cooling
Engine type	Diesel engine

Cylinder capacity	1,116.0 cm <sup>3</sup>
Tank capacity	36.0 l
Effective power	15.8 KW
Nominal Engine speed	2,500.0 1/min
Starter battery Voltage	12.0 V
Battery capacity (nom. value)	44.0 Ah
Engine Manufacturer	Yanmar

### Environment Data

Sound power LWA, guaranteed	93.0 dB(A)
-----------------------------	------------

### Operating Fluids

Oil volume	3.400 l
Cooling fluid volume	4.5 l
Hydraulic fluid volume	30.0 l

### Chassis

Traction drive	Axialpistonmotor with RGU
----------------	---------------------------

### Shipping and Storage

Shipping weight	2,553.0 kg
-----------------	------------

## Available engines

### ■ Yanmar 3TNV76-XNSV EU Stage V

Engine type	Diesel engine
Cylinder capacity	1,116 cm <sup>3</sup>
Fuel	Diesel EN 590
Effective power	15.8 KW
Nominal Engine speed	2,500 1/min
Maximum torque	66.1 Nm
Engine speed (max. torque)	1,800 1/min
Exhaust-gas limit	EU Stage V
Engine Manufacturer	Yanmar
Engine Designation	3TNV76-XNSV
Stroke	82 mlai
Bore	76 mlai

## Dimensions

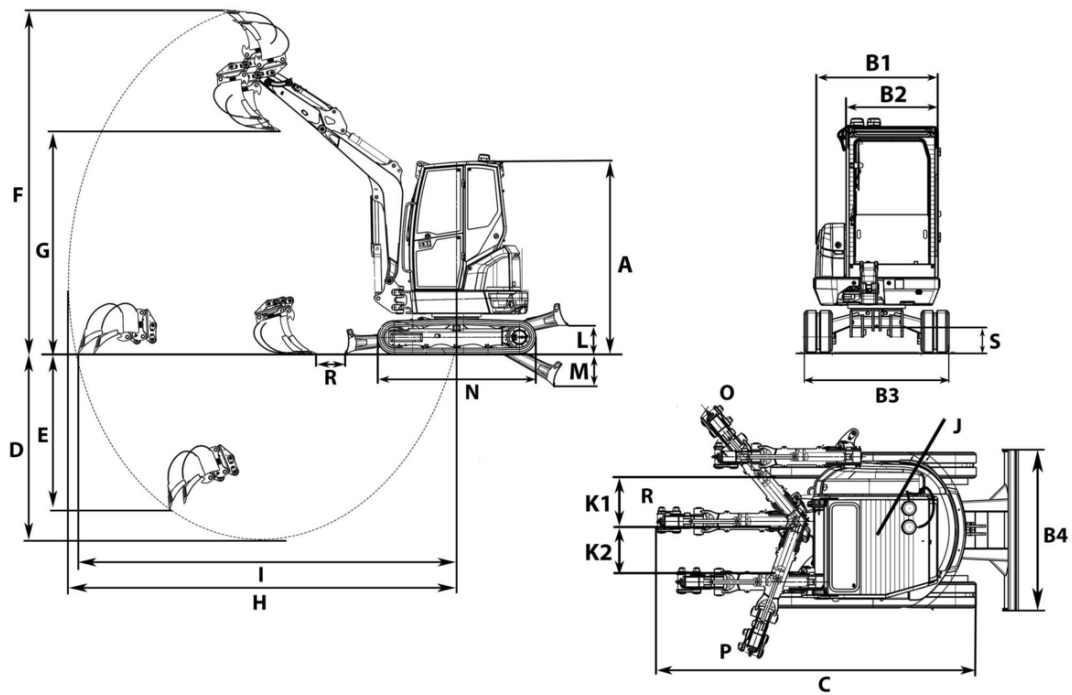

A	Height of canopy	2,414 mm
	Height of dozer blade	300 mm
B1	Width of upper carriage	1,366 mm
B2	Width of cab	986 mm
B3	Width travel gear	1,570 mm
B5	Width of dozer blade	1,570 mm
C2	Transport length short shovel arm	4,266 mm
D2	Digging depth max., short shovel arm	2,537 mm
E2	Piercing depth max., short shovel arm	1,949 mm
F2	Piercing height max., short shovel arm	4,176 mm
G2	Dumping height max., short shovel arm	2,847 mm
H2	Digging radius max., short shovel arm	4,624 mm
I2	Max. reach at ground level (short shovel arm)	4,490 mm
J1	Tail swing radius	770 mm
K1	Boom offset max. (to center of bucket right side)	765 mm
K2	Boom offset max. (to center of bucket left side)	531 mm
L1	Stacking height max. (dozer blade above surface)	387 mm
M1	Digging depth max. (dozer blade below surface)	412 mm
N1	Length travel drive	2,021 mm
O1	Max. swivel angle (arm system to the left)	75 °
O2	Max. swivel angle (arm system to the right)	50 °
P1	Track width	300 mm
Q1	Boom swing radius center	2,082 mm
Q2	Boom swing radius right	1,964 mm
Q3	Boom swing radius left	1,660 mm
R1	Distance bucket dozer blade, short shovel arm	267 mm