



KL14.5

Wheel loader

Performance in perfect proportion

KL14.5 is agile when it comes to movement, dynamic when it comes to power delivery and slim when it comes to design. With optimised power-to-weight ratio, low shipping weight and constantly higher payload, the machine is an ideal helper for stacking or loading material in narrow spaces.

Smart Driving Pro: Three driving modes that can be changed at the push of a button (PWR - Power Mode, ECO - Eco Mode and CSD - Slow Drive Mode) support the driver in the respective applications

Modern cabin design: Generous glass surfaces, a wide entry and exit, a functional side console incl. storage compartments and the optional air conditioning make it extremely comfortable

Maximum performance: The wheel loader is equipped with working hydraulics with 30 l/min. Optionally, even 60 l/min are feasible with the Powerflow option

Compact dimensions: With a width of 1.26 meters, the loader can get through almost any barn entrance and can be driven effortlessly on the sidewalk during maintenance work

Speed: Optionally, a speed of up to 30 km/h can be reached

Technical Data

■ Standard engine data

Engine manufacturer	Yanmar
Drive output	28.5 kW
Drive output	38.8 PS
at max. rpm	2,600 U/min
Cylinder capacity	1,568 cm ³
Exhaust standard level	V
Exhaust aftertreatment	DOC / DPF

■ Weights

Bucket capacity (standard bucket)	0.36 m ³
Payload (max.)	700 kg
Operating weight	1,900 - 2,400 kg
Payload (S=1.25)	900 kg
Thrusting force (max.)	1,160 daN
Lift capacity (max.)	11.6 kN
Tipping load (standard bucket)	1,400 kg
Tipping load (pallet fork)	1,125 kg

Tipping load (pallet fork)*	1,438 kg
-----------------------------	----------

■ Filling levels

Tank capacity for fuel	48 l
Tank capacity for hydraulic oil	39 l

■ Drive system

Travel speed Standard	0-20 km/h
Travel speed Option 1	0-30 km/h

■ Hydraulic system

Work hydraulics discharge volume (max.)	30 l/min
---	----------

■ Kinematics

Kinematics type	Z
-----------------	---

■ Steering

Steering angle max.	38 degree
---------------------	-----------

■ Noise characteristic values

Guaranteed sound power level LwA (cabin)	101 dB(A)
Measured sound power level LwA	99.1 dB(A)
Sound pressure level at the operator's ear	80 dB(A)

Dimensions

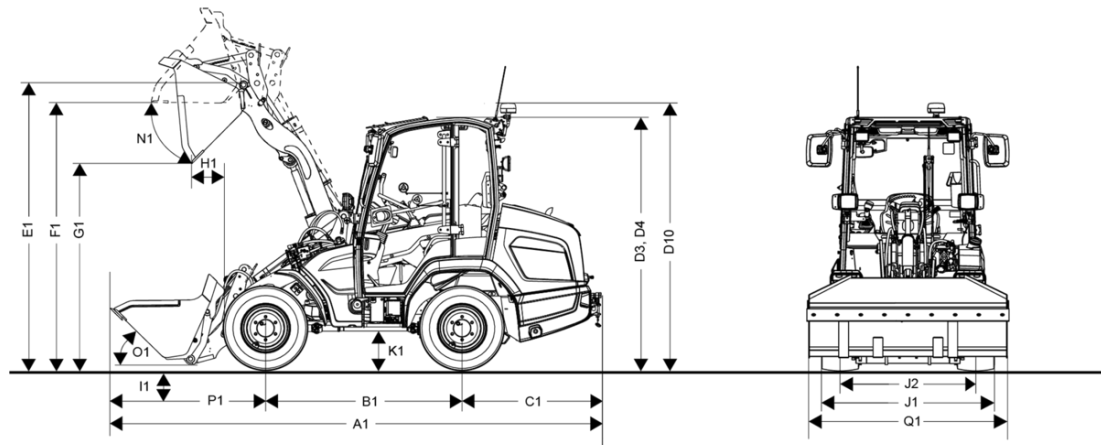

A1	Total length with standard attachment	4,090 mm
B1	Wheel base center	1,525 mm
C1	Rear overhang	1,140 mm
D2	Height with canopy down	2,020 mm
D3	Height with cab	2,170 mm
D4	Height with cab lowered	2,020 mm
D10	Total height with rotating beacon	2,490 mm
E1	Max. height blade pivot point	2,800 mm
F1	Load-over height	2,680 mm
G1	Dumping height	2,260 mm
H1	Dumping width	290 mm
I1	Digging depth	60 mm
J1	Total width	1,240 mm
J2	Track width	970 mm
L1	Turning radius outer edge wheels	2,000 mm
M1	Steering angle	38 °
M2	Swing angle	14 °
N1	Dumping angle at max. lifting height	40 °
O1	Dumping angle at ground level	20 °
P1	Distance center front axle to tooth tip	1,430 mm
Q1	Bucket width	1,400 mm
R1	Stacking height	2,630 mm