



WL110

Wheel Loader

Productivity in a new dimension

The largest machine in the compact wheel loader segment by Wacker Neuson: the wheel loader WL110. In the 1,8 m³ class, the machine is impressive in particular for its performance, which is demonstrated by its high tipping load and pushing power. Thanks to the large bucket capacity and high operating weight, the wheel loader is ideally suited for heavy but safe materials handling. The engine and the work hydraulics are designed for productivity, making the machine an efficient helper when it comes to safely and comfortably moving large volumes of material.

Highlights

- Eco Speed Pro: continuously variable hydrostatic transmission
- {30/40 km/h}{18.64/24.85 mph} speed
- Automatic air-conditioning system
- Clear 7-inch digital display
- Joystick console spring-mounted on the operator's seat

Technical Data

Standard engine data

Engine manufacturer	• Deutz
Motor type	TCD 4.1 S5
Cylinder	4
Drive output	115 kW
Drive output	156 PS
at max. rpm	2,300 U/min
Cylinder capacity	4,038 cm ³
Type of coolant	• Water/charge air
Exhaust standard level	• V
Exhaust aftertreatment	DOC/DPF/SCR

Electrical system

Operating voltage	12 V
Battery	185 Ah
Alternator	120 A

Weights

Bucket capacity (standard bucket)	1.80 m ³
Operating weight	11,250 kg
Tipping load with bucket – machine straight, loading frame horizontal	7,739 kg
Tipping load with bucket – machine pivoted, loading frame horizontal	6,674 kg

Tipping load with pallet fork – machine straight, loading frame horizontal	6,851 kg
--	----------

Tipping load with pallet fork – machine pivoted, loading frame horizontal	5,946 kg
---	----------

Driver's cab

Driver's cab	Cab
--------------	-----

Filling levels

Tank capacity for fuel	140 l
------------------------	-------

Tank capacity for hydraulic oil	125 l
---------------------------------	-------

Tank capacity for urea solution	12 l
---------------------------------	------

Drive system

Type of drive	Hydrostatic
---------------	-------------

drive unit	universal joint shaft
------------	-----------------------

Speed levels	3
--------------	---

Axle	PA 1900
------	---------

Travel speed Standard	0-20 km/h
-----------------------	-----------

Travel speed Option 1	0-30 km/h
-----------------------	-----------

Travel speed Option 2	0-40 km/h
-----------------------	-----------

Operating brake	Multi-disc brake on front axle acting on rear axle via universal joint shaft
-----------------	--

Parking brake	Electro-hydraulic multi-disc brakes with spring suspension in the front
---------------	---

	axle acting on rear axle via articulated universal joint shaft
--	--

Differential lock	100 % front axle + rear axle
-------------------	------------------------------

■ Hydraulic system

Drive hydraulics working pressure (max.)	480 bar
--	---------

Work hydraulics discharge volume (max.)	180 l/min
---	-----------

Work hydraulics working pressure (max.)	250 bar
---	---------

■ Kinematics

Kinematics type	Z
-----------------	---

Lifting cylinder	2
------------------	---

Tipping cylinder	1
------------------	---

Quick change system	hydraulic
---------------------	-----------

■ Steering

Steering type	Hydraulic articulated steering with oscillating axle
---------------	--

Steering cylinder	2
-------------------	---

Oscillating angle of the rear axle	± 12 degree
------------------------------------	-------------

■ Noise characteristic values

Average sound power level L _{WA} (cabin)	100.7 dB(A)
---	-------------

Guaranteed sound power level L _{WA} (cabin)	102 dB(A)
--	-----------

Specified sound pressure level L _{pA} (cabin)	70 dB(A)
--	----------

■ Other information

FSD = overhead guard
DPF = diesel particulate filter
DOC = diesel oxidation catalyst
SCR = selective catalytic reduction
Tipping load calculation pursuant to ISO 14397

Dimensions

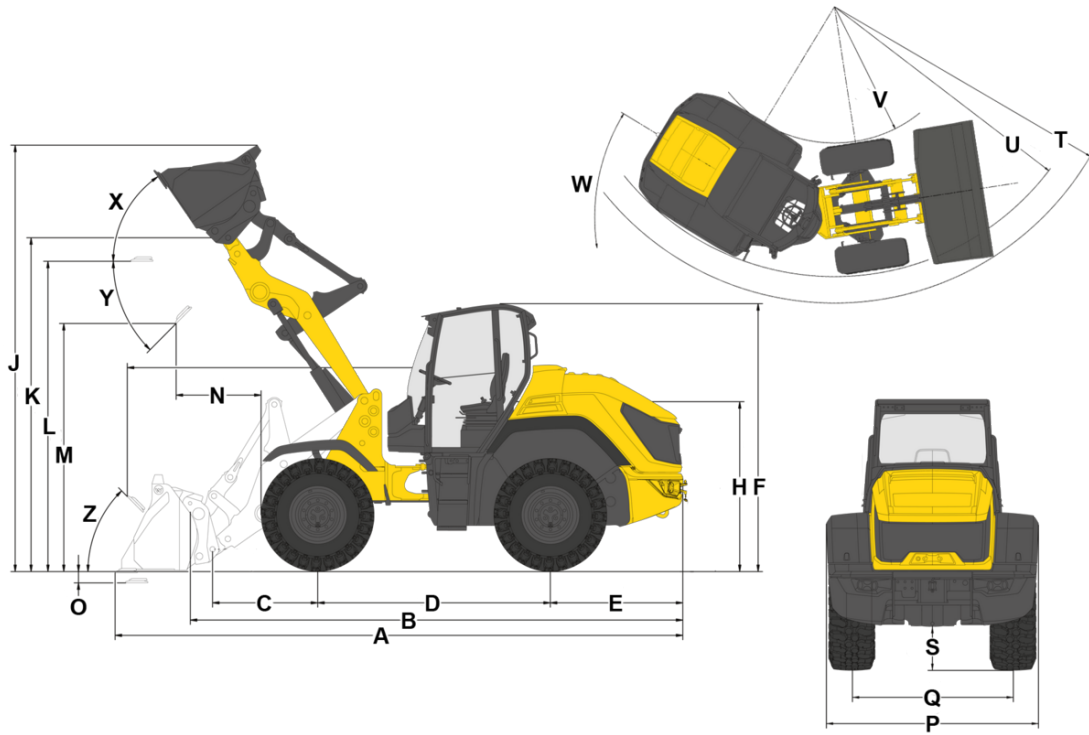

A	Total length	6,470 mm
B	Total length without bucket	5,610 mm
C	Bucket pivot point (to center of axle)	1,200 mm
D	Wheel base	2,660 mm
E	Rear overhang	1,520 mm
F	Height with cab	3,060 mm
H	Seat height	1,940 mm
J	Total working height	4,780 mm
K	Bucket pivot point (max. lift height)	3,820 mm
L	Load-over height	3,550 mm
M	Dumping height	2,860 mm
N	Reach (at M)	970 mm
O	Digging depth	136 mm
P	Total width	2,390 mm
Q	Track width	1,820 mm
S	Ground clearance	500 mm
T	Maximum external radius	5,370 mm
U	Radius on the outer edge	4,900 mm
V	Inner radius	2,450 mm
W	Articulation angle	40 °
X	Rollback angle at max. lift height	61 °
Y	Dumping angle	45 °
Z	Rollback angle on ground	45 °