



ST31

Compact Track Loader

Compact and Efficient

The ST31 matches the compact size of a medium frame with lift capacity of larger loaders. The vertical lift arm, 125 inch lift height and 74hp regeneration free engine, make the ST31 an accomplished material handler, perfect for use in a wide range of applications, from moving palletized material around a construction site to truck loading. The wide, double-steel reinforced tracks provide stability and reduced total cost of ownership.

Highlights

- Controls for Every Operator
- Two-speed transmission
- 5.7-inch Color Display
- Maximum Visibility
- Forward Tipping Cab

Technical Data

Hydraulic

Flow rate	19.8 gal/mi
Flow rate max.	29.9 gal/mi
Auxiliary hydraulics relief pressure	3,494.5 psi

Mechanical - Output Details

Ground Pressure	5.8 psi
Breakout force - tilt	5,300,097.0 lbf
Breakout force - lift	5,000.0 lbf
Tractive Effort max. at 100% effective force	9,873.6 lbf
Bucket Roll Back	1.6 s
Bucket Roll Out	2.1 s
Lift Arm Raise	3.7 s
Lift arm lower	2.5 s
Travel speed stage 1	6.5 m/H
Travel speed stage 2	9.7 m/H

Mechanical Details

Operating weight	8,240.9 lb
------------------	------------

Engine

Cooling	Water-cooling
Engine type	Diesel engine
Cylinder	4.0
Cylinder capacity	151.5 Inch ³
Oil filling max.	2.6 gal US
Operating power	74.3 hp
Operating Engine speed	2,750.0 1/min
Engine Manufacturer	Kohler

Operating Fluids

Hydraulic fluid volume	42.3 qt US
Fuel Tank capacity	35.0 gal US

Chassis

Tip Load	6,199.4 lb
Rated Operating Capacity at 50% Tip Load	3,099.7 lb
Rated Operating Capacity at 35% Tip Load	2,169.4 lb

Dimensions

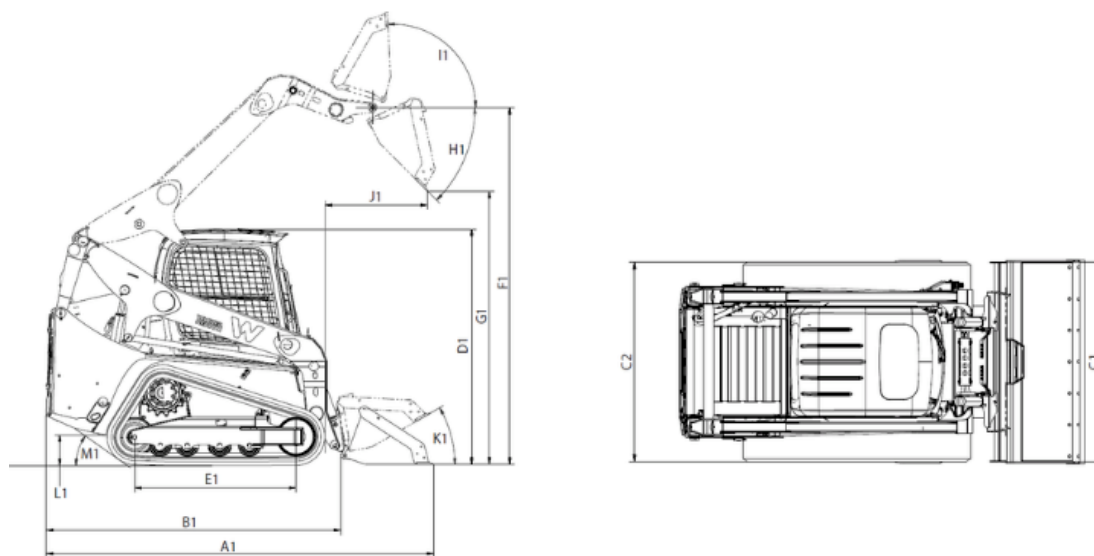

A1	Overall length with bucket	136.1 in
B1	Overall length without bucket	106.9 in
C1	Overall width with bucket	68.8 in
D1	Overall height	82.6 in
F1	Hinge pin height	128.5 in
G1	Dump height max.	100.8 in
H1	Dump angle	40 °
I1	Bucket rollback at max. stroke height	94.1 °
J1	Dump reach	38 in
L1	Ground clearance	9.1 in
M1	Angle of departure	33 °
C2	Overall width without bucket	64 in
E1	Length of track on ground	56.7 in
K1	Bucket rollback at ground level	30 °