



ST45

Compact Track Loader

Lift Higher, Load More

The ST45 is a large versatile machine. The vertical lift arm makes it perfect for unloading pallets of pavers or stone from trucks and distributing them around the jobsite. The 74hp regeneration-free engine provides easy maintenance and no interruptions to the workday, meaning more up time and greater productivity.

Highlights

- Controls for Every Operator
- Two-speed transmission
- 5.7-inch Color Display
- Forward Tipping Cab
- Maximum Visibility

Technical Data

Hydraulic

Flow rate	21.9 gal/mi
Flow rate max.	31.4 gal/mi
Auxiliary hydraulics relief pressure	3,480.0 psi

Mechanical - Output Details

Ground Pressure	4.5 psi
Breakout force - tilt	7,030,901.5 lbf
Breakout force - lift	8,160.1 lbf
Tractive Effort max. at 100% effective force	11,078.6 lbf
Travel speed stage 1	6.4 m/H
Travel speed stage 2	9.6 m/H

Mechanical Details

Operating weight	10,315.4 lb
------------------	-------------

Engine

Cooling	Water-cooling
---------	---------------

Engine type	Diesel engine
Cylinder	4.0
Cylinder capacity	207.5 Inch ³
Oil filling max.	4.1 gal US
Operating power	74.3 hp
Operating Engine speed	2,500.0 1/min
Battery capacity (nom. value)	950.0 Ah
Engine Manufacturer	Kohler

Operating Fluids

Hydraulic fluid volume	42.3 qt US
Fuel Tank capacity	35.1 gal US

Chassis

Tip Load	8,999.3 lb
Rated Operating Capacity at 35% Tip Load	3,150.4 lb

Dimensions

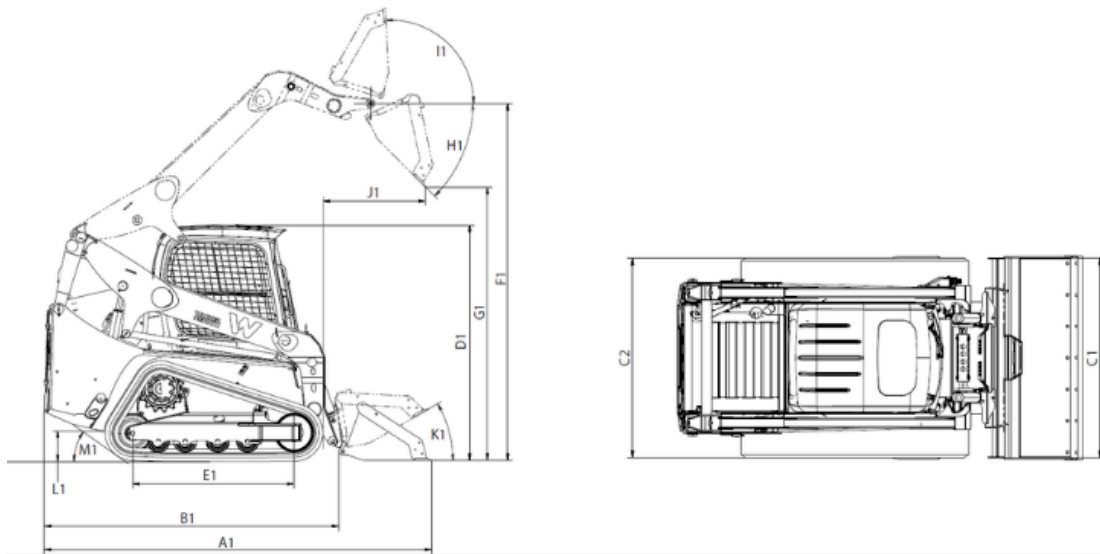

A1	Overall length with bucket	149.4 in
B1	Overall length without bucket	120 in
C1	Overall width with bucket	80.5 in
D1	Overall height	84.6 in
F1	Hinge pin height	136.3 in
G1	Dump height max.	108.5 in
H1	Dump angle	40 °
I1	Bucket rollback at max. stroke height	94 °
J1	Dump reach	37.1 in
L1	Ground clearance	10.7 in
M1	Angle of departure	29 °
C2	Overall length without bucket	78 in
E1	Length of track on ground	64.2 in
K1	Bucket rollback at ground level	30 °