



DT10e

Electric Track Dumper

The electric dumper for all occasions

The two low-installed batteries make the machine very stable even in an inclined position. The electric drive system also greatly reduces the service and energy costs. With a charge time of 8 hours and a running time of 8 hours at once, it fits into your average workday perfectly - charge at night and get going in the morning!

Highlights

- Electric drive system
- Unlimited performance
- Battery charger on the machine
- Chargeable at a normal 220 V socket
- Very low noise pollution

Technical Data

Hydraulic

Hydraulic pump	ZRP
Flow rate max.	5.0 l/min

Mechanical - Output Details

Travel speed	4.0 km/h
--------------	----------

Mechanical Details

Length	1,803.0 mm
Width	790.0 mm
Height	1,280.0 mm
Weight	680.00 kg
Payload max.	1,000.0 kg
Skip capacity levelled	367.0 l
Skip capacity heaped	427.0 l
Skip capacity waterlevel	166.0 l
Operating weight (min.-max.)	890.0 - 1,030.0 kg

Motor

Motor type	Asynchronous motor
Nominal power	4.00 KW
Nominal current	33.0 A
Nominal voltage	80.0 V
Nominal speed	1,800.0 1/min

Environment Data

Sound level LpA	74.0 dB(A)
Sound level LpA (Standard)	ISO 6396
Sound power LWA, guaranteed	94.0 dB(A)
Sound power LWA (Standard)	ISO 6395

Electrical System

Charging Time	8.0 - 10.0 h
Type of battery	LiFePO4

Shipping and Storage

Shipping weight	815.0 kg
-----------------	----------

Dimensions

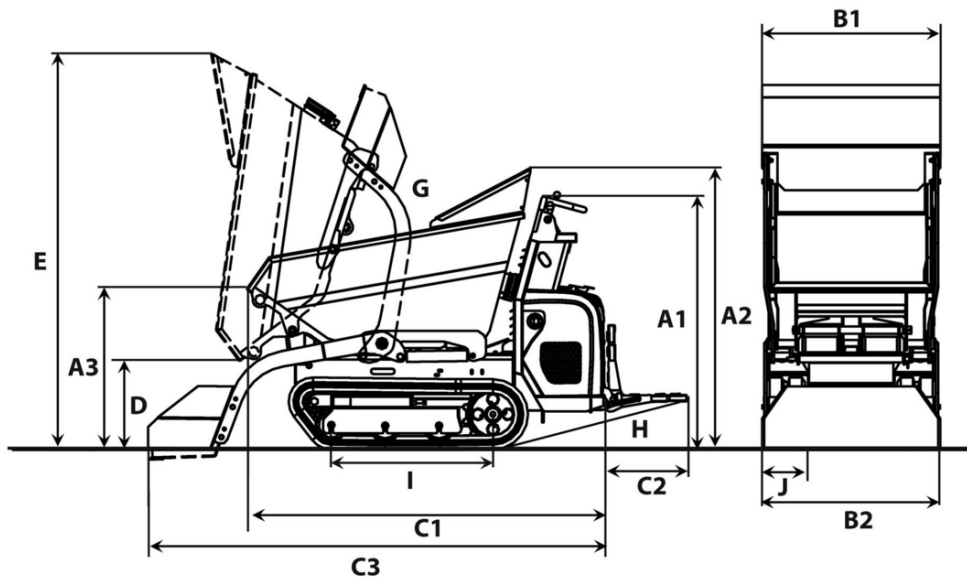

		Front tip skip	High tip skip
A1	Height above operator's stand	1,270 mm	1,270 mm
A2	Height over skip hand guard	1,365 mm	1,365 mm
A3	Height front edge of skip	801 mm	1,111 mm
	Height front edge of high tip skip raised		1,710 mm
B1	Width of skip	790 mm	764 mm
B2	Width of undercarriage	830 °	790 mm
	Width with self-loading equipment	830 mm	830 mm
C1	Total length without footboard	1,803 mm	1,685 mm
C2	Length footboard	392 mm	392 mm
C3	Length with self-loading equipment, without footboard	2,248 mm	2,208 mm
D	Dumping height max.	474 mm	863 mm
	Dumping height max., high tip skip raised		1,467 mm
E	Skip height tilted	1,905 mm	2,003 mm
	Skip height tilted, high tip skip raised		2,610 mm
G	Dumping angle	70 °	82 °
H	Rollback angle footboard	14 °	15 °
I	Length chain stand	875 mm	875 mm