



## ST37

### Compact Track Loader

#### Powerful and Productive

The ST37 offers the performance more in line with a large frame loader but in a more compact, nimble package. Standard features include switchable EH joystick controls, 2-speed travel with auto shift, color display, and battery disconnect which provide comfort and performance to the operator. The lift capacity of 3,700 lbs gives the user the flexibility to work in a variety of jobs with ease using one machine to get the job done.

### Highlights

- Controls for Every Operator
- Two-speed transmission
- 5.7-inch Color Display
- Forward Tipping Cab
- Maximum Visibility

### Technical Data

#### Hydraulic

Flow rate	23.0 gal/mi
Flow rate max.	33.1 gal/mi
Auxiliary hydraulics relief pressure	4,930.0 psi

#### Mechanical - Output Details

Ground Pressure	5.8 psi
Breakout force - tilt	5,300,097.0 lbf
Breakout force - lift	5,000.0 lbf
Tractive Effort max. at 100% effective force	9,873.6 lbf
Bucket Roll Back	1.6 s
Bucket Roll Out	2.1 s
Lift Arm Raise	3.7 s

Lift arm lower	2.5 s
Travel speed stage 1	5.8 m/H
Travel speed stage 2	8.8 m/H

#### Mechanical Details

Operating weight	8,095.4 lb
------------------	------------

#### Operating Fluids

Hydraulic fluid volume	42.3 qt US
Fuel Tank capacity	32.8 gal US

#### Chassis

Tip Load	7,400.9 lb
Rated Operating Capacity at 50% Tip Load	3,699.4 lb
Rated Operating Capacity at 35% Tip Load	2,590.4 lb

## Dimensions

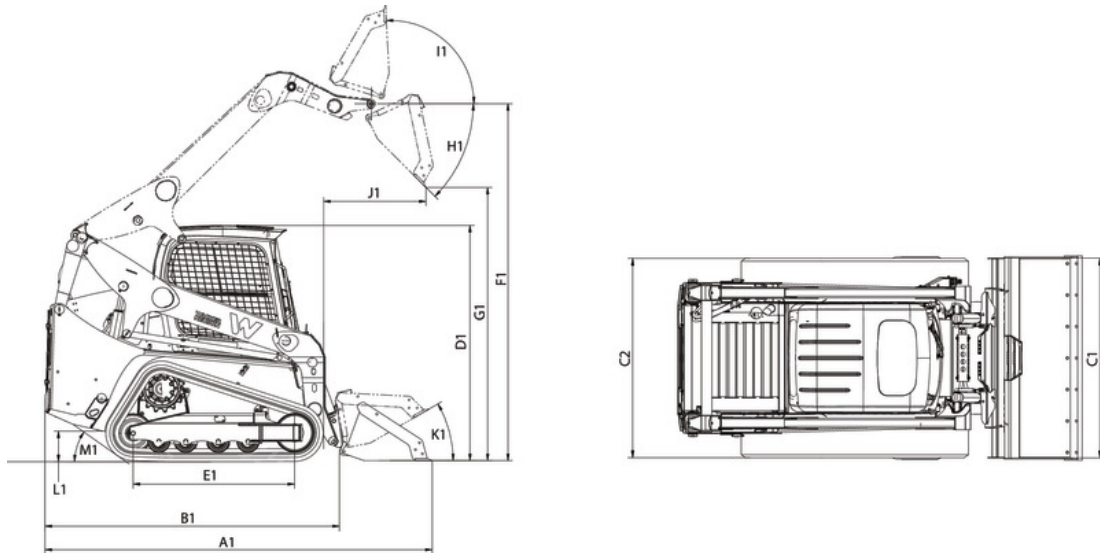

A1	Overall length with bucket	136.1 in
B1	Overall length without bucket	106.9 in
C1	Overall width with bucket	75.8 in
D1	Overall height	82.8 in
F1	Hinge pin height	128.5 in
G1	Dump height max.	100.8 in
H1	Dump angle	40 °
I1	Bucket rollback at max. stroke height	94.1 °
J1	Dump reach	38 in
L1	Ground clearance	9.1 in
M1	Angle of departure	33 °
C2	Overall width without bucket	72 in
E1	Length of track on ground	58.9 in
K1	Bucket rollback at ground level	30 °