



## DW50 Wheel Dumper

Optimized for maximum safety and performance

An optimized skip format for even greater water volume and minimized risk of damage when loading and unloading with the excavator bucket, as well as a variety of details that clearly make it outstanding in terms of comfort and safety, make up the DW50. The operator benefits from many storage options, some also lockable, and safety features such as cameras in both directions, rear LED lights incl. dynamic turn signals as well as cruise control and a large clear display. This makes safe work fun.

### Highlights

- Seat belt monitoring
- Sturdy skip guard
- Rear LED lights incl. dynamic turn signals
- Auto-stop function
- Active Sense Control

### Technical Data

#### Hydraulic

Operating pressure hydraulics	220.0 bar
Hydraulic pump	ZRP
Flow rate	58.0 l/min
Tank capacity	40.0 l

#### Mechanical - Output Details

Travel speed	25.0 km/h
Travel speed (Option)	28.0 km/h

#### Mechanical Details

Length	4,412.0 mm
Width	1,905.0 mm
Height	2,813.0 mm
Payload	5,000.0 kg
Skip capacity levelled	2,000.0 l
Skip capacity heaped	2,650.0 l
Skip capacity waterlevel	1,320.0 l
Pendulum angle	15.0 °
Operating weight (min.-max.)	3,235.0 - 3,642.0 kg

#### Engine

Cooling	Water-cooling
Engine type	Turbodieselengine

Cylinder	3.0
Cylinder capacity	2,200.0 cm <sup>3</sup>
Fuel	HVO EN15940
Tank capacity	60.0 l
Effective power	44.5 KW
Nominal Engine speed	2,300.0 1/min
Engine Manufacturer	Deutz
Engine Designation	TD 2.2 L3

#### Environment Data

Sound power LWA, guaranteed	101.0 dB(A)
-----------------------------	-------------

#### Chassis

Turning radius	4,280.0 mm
Articulation angle	37.0 °
Traction drive	4WD hydrostatic
Hydraulic Pump	Axialpistonpump
Operating pressure	470.0 bar
Flow rate	123.0 l/min
Tires	12.5-18/16 MPT-01

#### Shipping and Storage

Shipping weight	3,106.0 kg
-----------------	------------

## Available engines

### ■ 55,4 kW Diesel engine (Stage 5)

Cooling	Water-cooling
Engine type	Turbodieselengine air cooling
Cylinder	4
Cylinder capacity	2,925 cm3
Effective power	55.4 KW
Nominal Engine speed	2,300 1/min
Starter battery Voltage	12 µg/l
Engine Manufacturer	Deutz
Engine Designation	TD2.9 L4
Stroke	110 mlai

Bore	92 mlai
------	---------

### ■ 44,5 kW Diesel engine (Stage 5)

Cooling	Water-cooling
Engine type	Turbodieselengine
Cylinder	4
Cylinder capacity	2,200 cm3
Effective power	44.5 KW
Nominal Engine speed	2,300 1/min
Starter battery Voltage	12 µg/l
Engine Manufacturer	Deutz
Engine Designation	TD 2.2 L3

## Dimensions

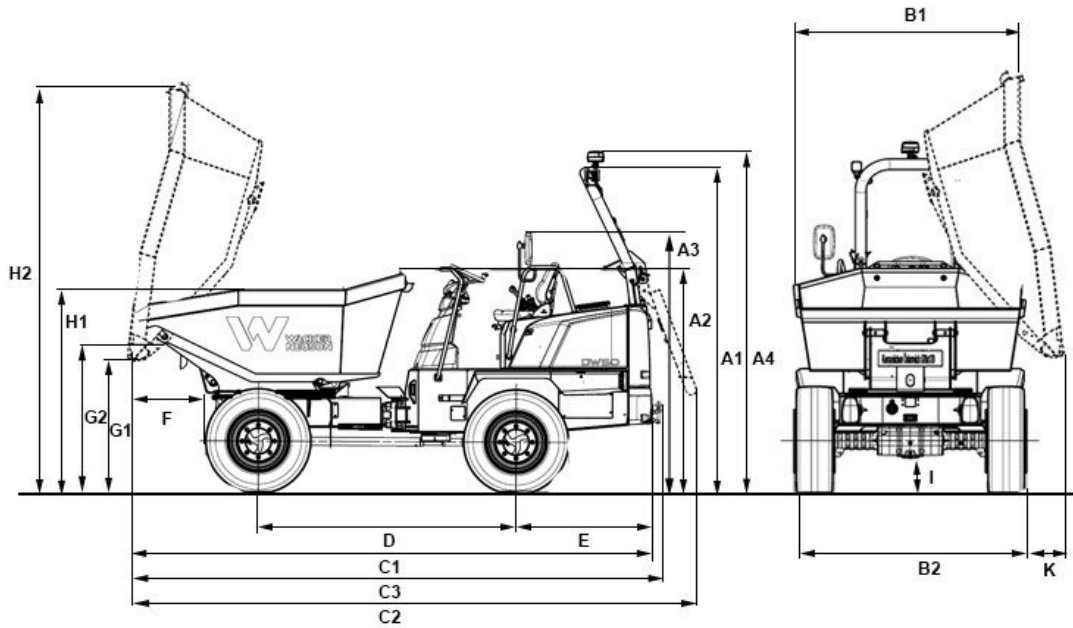

A1	Height ROPS	2,813 mm
A2	Height of ROPS tilted	1,974 mm
A3	Height above operator's stand	2,189 mm
A4	Height ROPS with rotating beacon	2,924 mm
B2	Width of vehicle	1,926 mm
B1	Width of skip	1,926 mm
C1	Total length ROPS	4,412 mm
C2	Total length ROPS tilted	4,790 mm
C3	Total length with towing device	4,498 mm
D	Wheel base	2,190 mm
E	Rear overhang	1,157 mm
F	Dumping width	570 mm
G1	Dumping height max.	1,141 mm
G2	Load-over height	1,291 mm
H1	Skip height	1,747 mm
H2	Skip height tilted	3,509 mm
I	Ground clearance	312 mm
	Dumping angle	48 °
K	Dumping width lateral	316 mm