



ET20

Tracked conventional excavator

The all-rounder for more flexibility and efficiency.

The ET20 is a compact partner for gardening and landscaping, new construction areas and municipal construction sites. The load-sensing hydraulics deliver constant power regardless of the load, while the telescopic undercarriage combines accessibility and stability. AUX II AUX III enable simultaneous operation of Powertilt and gripper. Auto-idle, joystick control and pressure release increase convenience and efficiency. With VDS, the cab remains upright even on slopes - for precise work and clean edges.

Highlights

- Parallel operable control circuits AUX II &
- VDS Vertical Digging System
- Hydraulic telescopic travel gear with dozer blade extension
- Comfort that noticeably increases performance
- Up to 5 additional control circuits ex work

Technical Data

Hydraulic

Operating pressure hydraulics	240.0 bar
Hydraulic pump	Axial piston displacement pump
Flow rate	66.0 l/min

Mechanical - Output Details

Travel speed	5.0 km/h
--------------	----------

Mechanical Details

Length	4,063.0 - 4,069.0 mm
Width	990.0 - 1,300.0 mm
Height	2,348.0 mm
Operating weight (min.-max.)	2,000.0 - 2,340.0 kg
Digging depth (max.)	2,703.0 mm

Engine

Cooling	Water-cooling
Engine type	Diesel engine

Cylinder	3.0
Cylinder capacity	1,266.0 cm ³
Fuel	HVO EN15940
Effective power	14.6 KW
Nominal Engine speed	2,400.0 1/min
Engine Manufacturer	Yanmar
Engine Designation	3TNV80F-NPWN

Environment Data

Sound power LWA, guaranteed	93.0 dB(A)
-----------------------------	------------

Operating Fluids

Fuel Tank capacity	29.5 l
--------------------	--------

Chassis

Operating pressure	240.0 bar
--------------------	-----------

Shipping and Storage

Shipping weight	1,840.0 - 2,180.0 kg
-----------------	----------------------

Dimensions

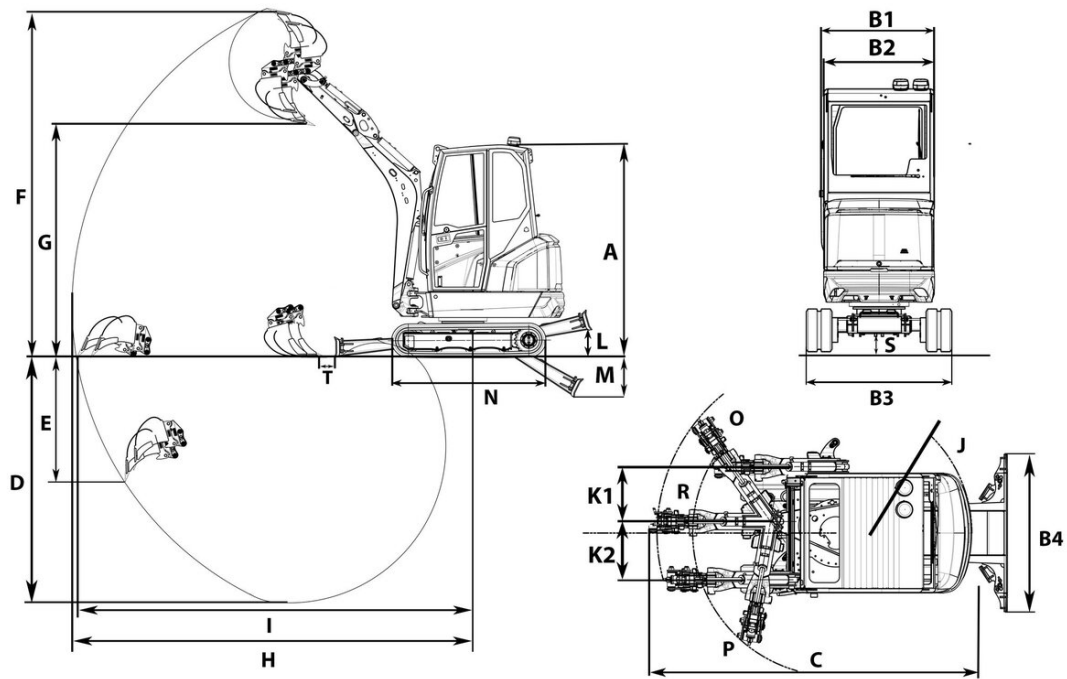

A	Height with cab	2,348 mm	2,449 mm
B1	Width of upper carriage	990 mm	990 mm
B2	Width of cab	990 mm	990 mm
B3	Width travel gear retracted	990 mm	990 mm
	Width travel gear extended	1,300 mm	1,300 mm
C	Transport length short shovel arm	3,821 mm	4,066 mm
	Transport length long shovel arm	4,063 mm	4,057 mm
D	Digging depth max., short shovel arm	2,543 mm	2,443 mm
	Digging depth max., long shovel arm	2,703 mm	2,603 mm
E	Piercing depth max., short shovel arm	1,241 mm	1,140 mm
	Piercing depth max., long shovel arm	1,371 mm	1,270 mm
F	Piercing height max., short shovel arm	3,739 mm	3,840 mm
	Piercing height max., long shovel arm	3,853 mm	3,954 mm
G	Dumping height max., short shovel arm	2,557 mm	2,657 mm
H	Digging radius max., short shovel arm	4,158 mm	4,158 mm
I	Max. reach at ground level (short shovel arm)	4,106 mm	4,087 mm
J	Tail swing radius	1,123 mm	1,123 mm
K1	Boom offset max. (to center of bucket right side)	548 mm	548 mm
K2	Boom offset max. (to center of bucket left side)	386 mm	386 mm
L	Stacking height max. (dozer blade above surface)	305 mm	367 mm
M	Digging depth max. (dozer blade below surface)	437 mm	374 mm
N	Length travel drive	1,701 mm	1,701 mm
O	Boom swing radius right	1,479 mm	1,479 mm
P	Boom swing radius left	1,183 mm	1,183 mm
R	Boom swing radius center	1,579 mm	1,579 mm
S	Ground clearance	172 mm	164 mm
T	Distance bucket dozer blade, short shovel arm	189 mm	200 mm
	Distance bucket dozer blade, long shovel arm	82 mm	92 mm