



EZ26

Tracked Zero Tail Excavator

Powerful all-rounder

The EZ26 guarantees flexibility and user-friendliness with high performance features. The low weight allows transport, including of attachments, by car trailer. The wide field of vision around the machine from the cab increases the safety of the operator and the construction site environment. It also ensures constant control of the working environment. The simultaneously high performance and high operating comfort thanks to the wide access, jog-dial operating system and clear machine display make the EZ26 a feel-good zone for the operator.

Highlights

- Air-conditioning system
- Very good all-round visibility
- Easy transportation by car trailer
- Zero Tail
- Auto-stop function
- Optimized hydraulics or engine-pump management

Technical Data

Hydraulic

Operating pressure hydraulics	240.0 bar
-------------------------------	-----------

Mechanical - Output Details

Nominal rotation speed	2,350.0 1/min
Travel speed	4.3 km/h

Mechanical Details

Length	4,199.0 mm
Width	1,550.0 mm
Height	2,412.0 mm
Operating weight (min.-max.)	2,455.0 - 3,358.0 kg
Digging depth (max.)	2,803.0 mm

Engine

Cooling	Water-cooling
Engine type	Diesel engine

Cylinder capacity	1,266.0 cm ³
-------------------	-------------------------

Inclined position max.	30.0 °
------------------------	--------

Fuel	HVO EN15940
------	-------------

Effective power	14.6 KW
-----------------	---------

Nominal Engine speed	2,350.0 1/min
----------------------	---------------

Starter battery Voltage	12.0 V
-------------------------	--------

Engine Manufacturer	Yanmar
---------------------	--------

Engine Designation	3TNV80F-NPWN
--------------------	--------------

Environment Data

Sound power LWA, guaranteed	93.0 dB(A)
-----------------------------	------------

Chassis

Traction drive	axial piston motor
----------------	--------------------

Shipping and Storage

Shipping weight	2,480.0 - 2,700.0 kg
-----------------	----------------------

Dimensions

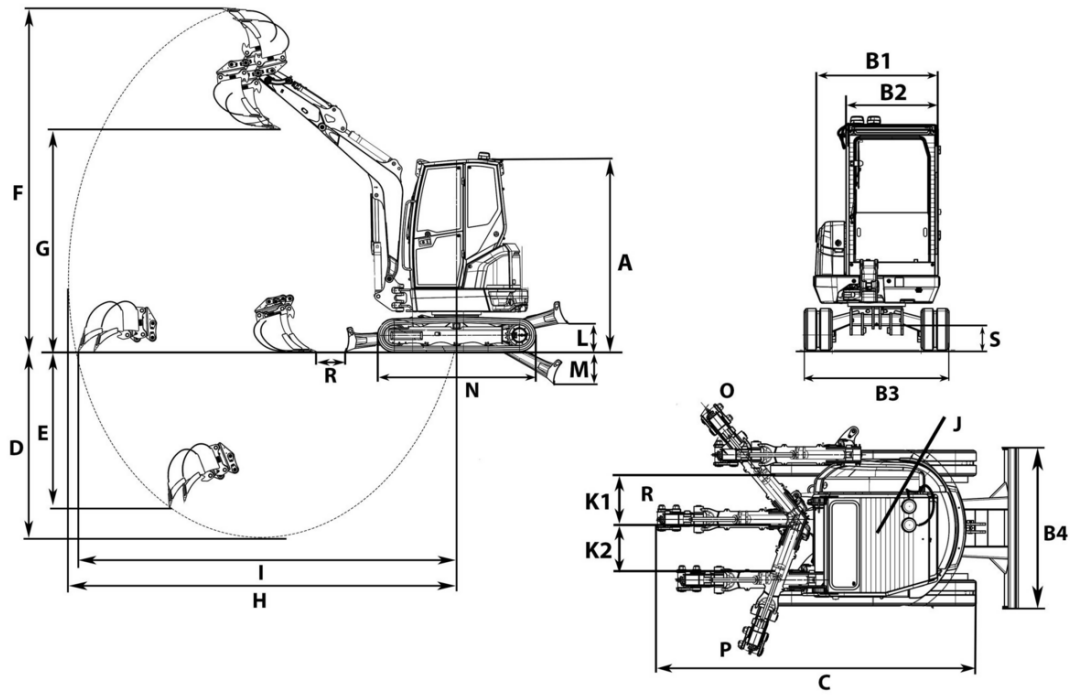

A	Height	2,412 mm
	Total height with rotating beacon	2,502 mm
B1	Width of upper carriage	1,350 mm
B2	Width of cab	980 mm
B3	Width travel gear	1,550 mm
C	Transport length short shovel arm	4,199 mm
	Transport length long shovel arm	4,212 mm
D	Digging depth max., short shovel arm	2,603 mm
	Digging depth max., long shovel arm	2,803 mm
E	Piercing depth max., short shovel arm	1,124 mm
	Piercing depth max., long shovel arm	1,281 mm
F	Piercing height max., short shovel arm	4,151 mm
	Piercing height max., long shovel arm	4,280 mm
G	Dumping height max., short shovel arm	2,764 mm
	Dumping height max., long shovel arm	2,893 mm
H	Digging radius max., short shovel arm	4,622 mm
	Digging radius max., long shovel arm	4,813 mm
I	Max. reach at ground level (short shovel arm)	4,508 mm
	Max. reach at ground level (long shovel arm)	4,706 mm
J	Tail swing radius	819 mm
	Tail swing radius with tail weight	896 mm
K1	Boom offset max. (to center of bucket right side)	622 mm
K2	Boom offset max. (to center of bucket left side)	584 mm
L	Stacking height max. (dozer blade above surface)	374 mm
M	Digging depth max. (dozer blade below surface)	409 mm
N	Length travel drive	1,982 mm
O	Max. swivel angle (arm system to the right)	50 °
P	Max. swivel angle (arm system to the left)	70 °
R	Boom swing radius center	2,102 mm
S	Ground clearance	263 mm