



DW90

Wheel Dumper

The power package for the safety-conscious

The outstanding operator environment and the high level of safety features contribute to this exceptional material handler with a payload of 9,000 kg. The high skip volume provides space for a lot of material, and reduces the turnaround times on the construction site. Those who have a lot to transport, while valuing safety and performance, are on the right path with the DW90. And all that with up to 25 km/h. The cameras mounted on both sides with washing system provide the respective image on the 7-inch color display and thereby increase the safety of the machine's surroundings with a high level of visibility. Furthermore, it is equipped ex works with skip and tilt monitoring, as well as optionally with a hill-hold function.

Highlights

- Inclination monitoring
- Skip monitoring
- Hydrostatic 4-wheel drive with automatic ECO mode
- Hill-Hold function
- Active Sense Control

Technical Data

Hydraulic

Operating pressure hydraulics	240.0 bar
Hydraulic pump	ZRP
Flow rate	59.0 l/min
Tank capacity	64.0 l

Mechanical - Output Details

Travel speed	25.0 km/h
--------------	-----------

Mechanical Details

Length	4,729.0 mm
Width	2,400.0 mm
Height	3,416.0 mm
Weight	4,478.00 kg
Payload	9,000.0 kg
Skip	Front tip skip
Skip capacity levelled	3,750.0 l
Skip capacity heaped	4,600.0 l
Skip capacity waterlevel	2,400.0 l
Pendulum angle	11.0 °
Operating weight (min.-max.)	4,324.0 - 4,944.0 kg

Engine

Cooling	Water-cooling
Engine type	Turbodiesel engine air cooling
Cylinder	4.0
Cylinder capacity	2,925.0 cm ³
Fuel	HVO EN15940
Tank capacity	83.0 l
Effective power	55.4 KW
Nominal Engine speed	2,300.0 1/min
Standard (Effective power)	ISO 3046
Exhaust-gas limit	EU Stage V
Starter battery Voltage	12.0 V
Engine Manufacturer	Deutz
Engine Designation	TD2.9 L4

Environment Data

Sound power LWA, guaranteed	101.0 dB(A)
-----------------------------	-------------

Operating Fluids

Fuel Tank capacity	70.0 l
--------------------	--------

■ Chassis

Turning radius	5,750.0 mm
Articulation angle	28.0 °
Traction drive	4WD hydrostatic ECO

Hydraulik Pump	Axialpistonpump
Operating pressure	450.0 bar
Flow rate	171.0 l/min
Tires	400/55R22.5

Dimensions

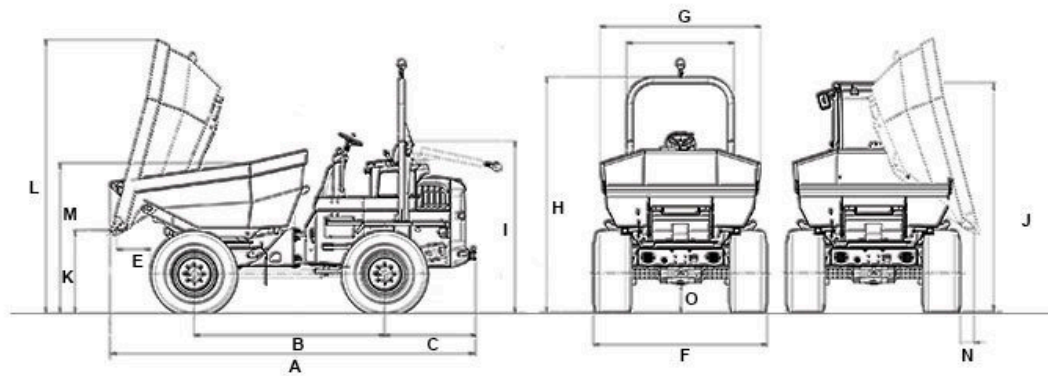

		Front tip skip
A	Total length	4,729 mm
B	Wheel base	2,700 mm
C	Rear overhang	1,263 mm
E	Dumping width	514 mm
F	Width of vehicle	2,420 mm
G	Width of skip	2,486 mm
H	Height ROPS	3,280 mm
I	Height of ROPS tilted	2,618 mm
J	Height with cab	3,081 mm
K	Dumping height max.	374 mm
L	Skip height tilted	2,580 mm
M	Skip height	2,003 mm
O	Ground clearance	396 mm