



## ST27

### Compact Track Loader

#### Small But Fierce

The ST27 offers a compact design, outstanding visibility and operator comfort features that make it a perfect fit for any job. The trim package, low weight and ability to lift heavier loads, compared to similar machines in this class, make it especially productive for smaller job sites. The ST27 is powered by a Kohler turbocharged engine offering high horsepower, superior torque and large fuel capacity to operate longer and get more done. The vertical lift arms allow excellent lift and dump height for maximum efficiency and flexibility on the job site.

### Highlights

- Controls for Every Operator
- Two-speed transmission
- 5.7-inch Color Display
- Maintenance and Filter Free After-treatment
- Expansive Maintenance Access

### Technical Data

#### Hydraulic

Flow rate	73.0 l/min
Flow rate max.	109.0 l/min
Auxiliary hydraulics relief pressure	240.0 bar

#### Mechanical - Output Details

Ground Pressure	0.3 bar
Breakout force - tilt	24,039.0 kN
Breakout force - lift	21,277.0 N
Tractive Effort max. at 100% effective force	33,259.0 N
Bucket Roll Back	2.1 s
Bucket Roll Out	2.2 s
Lift Arm Raise	3.3 s
Lift arm lower	2.8 s
Travel speed stage 1	10.3 km/h
Travel speed stage 2	14.7 km/h

#### Mechanical Details

Operating weight	3,334.0 kg
------------------	------------

#### Engine

Cooling	Water-cooling
Cylinder	4.0
Oil filling max.	9.5 l
Power rating max.	55.4 KW
Operating Engine speed	2,600.0 1/min
Starter battery Voltage	12.0 V
Engine Manufacturer	Kohler
Engine Designation	KDI2504TCR

#### Operating Fluids

Hydraulic fluid volume	29.0 l
Fuel Tank capacity	103.0 l

#### Chassis

Tip Load	2,450.0 kg
Rated Operating Capacity at 35% Tip Load	857.0 kg

## Dimensions

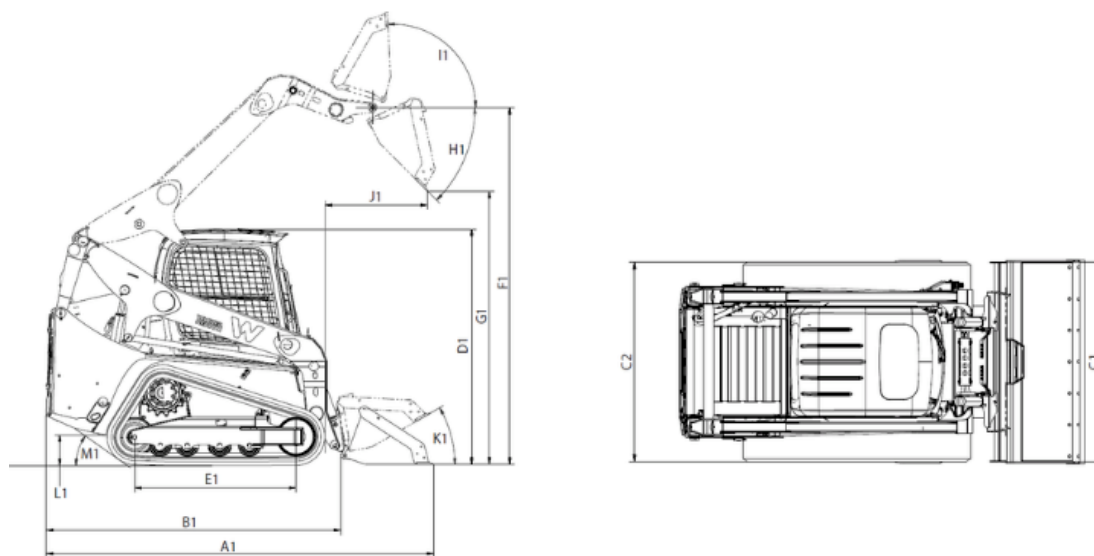

A1	Overall length with bucket	3,364 mm
B1	Overall length without bucket	2,605 mm
C1	Overall width with bucket	1,612.9 mm
C2	Overall width without bucket	1,524 mm
D1	Overall height	2,028 mm
E1	Length of track on ground	1,351 mm
F1	Hinge pin height	3,047 mm
G1	Dump height max.	2,395 mm
H1	Dump angle	37 °
I1	Bucket rollback at max. stroke height	95.5 °
J1	Dump reach	994.9 mm
K1	Bucket rollback at ground level	30 °
M1	Angle of departure	29.9 °