



1390e Hoftrac

Technical data

■ Electric motor

Motor traction drive (ECE R085)	33,1 kW
Motor work hydraulics (ECE R085)	21.2 kW

■ Electrical system

Operating voltage	12 V
-------------------	------

■ Weights

Operating weight	2,730 - 3,130 kg
Thrust force (max.)	2,158 - 3,492 daN
Lift capacity (max.)	2,448 - 3,592 daN
Tipping load with bucket – machine straight, loading frame horizontal	1,670 - 2,110 kg
Tipping load with bucket – machine pivoted, loading frame horizontal	1,410 - 1,820 kg
Tipping load with bucket - machine straight, loading frame in lowest position	2,470 - 3,350 kg
Tipping load with bucket - machine pivoted, loading frame in lowest position	2,090 - 2,880 kg
Tipping load with pallet fork – machine straight, loading frame horizontal	1,370 - 1,960 kg
Tipping load with pallet fork – machine pivoted, loading frame horizontal	1,160 - 1,710 kg
Tipping load with pallet fork - machine straight, transport position	1,610 - 2,220 kg
Tipping load with pallet fork - machine pivoted, transport position	1,370 - 1,930 kg

■ Driver's cab

Driver's cab	FSD (eps, cabin)
--------------	------------------

■ Filling levels

Tank capacity for hydraulic oil	30 l
---------------------------------	------

■ Drive system

Type of drive	Electrical
drive unit	universal joint shaft
Speed levels	2

Axle	PA940
Travel speed Standard	0-15 km/h
Travel speed Option 1	0-20 km/h
Travel speed Option 2	0-25 km/h
Operating brake	Multi-disc brake on front axle acting on rear axle via universal joint shaft
Parking brake	Electric parking brake with hill-hold function
Differential lock	100% VA + HA (option)

■ Hydraulic system

Work hydraulics discharge volume (max.)	44 l/min
Work hydraulics working pressure (max.)	210 bar

■ Kinematics

Kinematics type	P (PZ)
Lifting cylinder	2
Tipping cylinder	1
Quick change system	hydraulic

■ Steering

Steering type	hydraulically activated articulated pendulum steering
Steering cylinder	1
Oscillating angle	± 8 degree

■ Noise characteristic values

Average sound power level LwA (operator's canopy)	83.9 dB(A)
Guaranteed sound power level LwA (operator's canopy)	85 dB(A)
Specified sound pressure level LpA (operator's canopy)	60 dB(A)
Average sound power level LwA (cabin)	83.9 dB(A)
Guaranteed sound power level LwA (cabin)	85 dB(A)
Specified sound pressure level LpA (cabin)	64 dB(A)

■ Standard battery

Battery technology	Lithium-ion
Battery voltage class	96 V
Battery capacity	14.1 kWh
Battery weight	153 kg
On-board charging capacity (max.)	3 kW
Loading time (0-100%)	4,7 - 6 h
Loading time (20-80%)	2,9 h
Running time up to	2,5 h

■ Battery Option 1

Battery technology	Lithium-ion
Battery voltage class	96 V
Battery capacity	18.0 kWh
Battery weight	186 kg

On-board charging capacity (max.)	6 kW
Loading time (0-100%)	3,2 - 7,5 h
Loading time (20-80%)	1,8 h
Running time up to	3,5 h

■ Battery Option 2

Battery technology	Lithium-ion
Battery voltage class	96 V
Battery capacity	28.0 kWh
Battery weight	244 kg
On-board charging capacity (max.)	6 kW
Loading time (0-100%)	5,5 - 11,5 h
Loading time (20-80%)	2,7 h
Running time up to	5,3 h

Dimensions

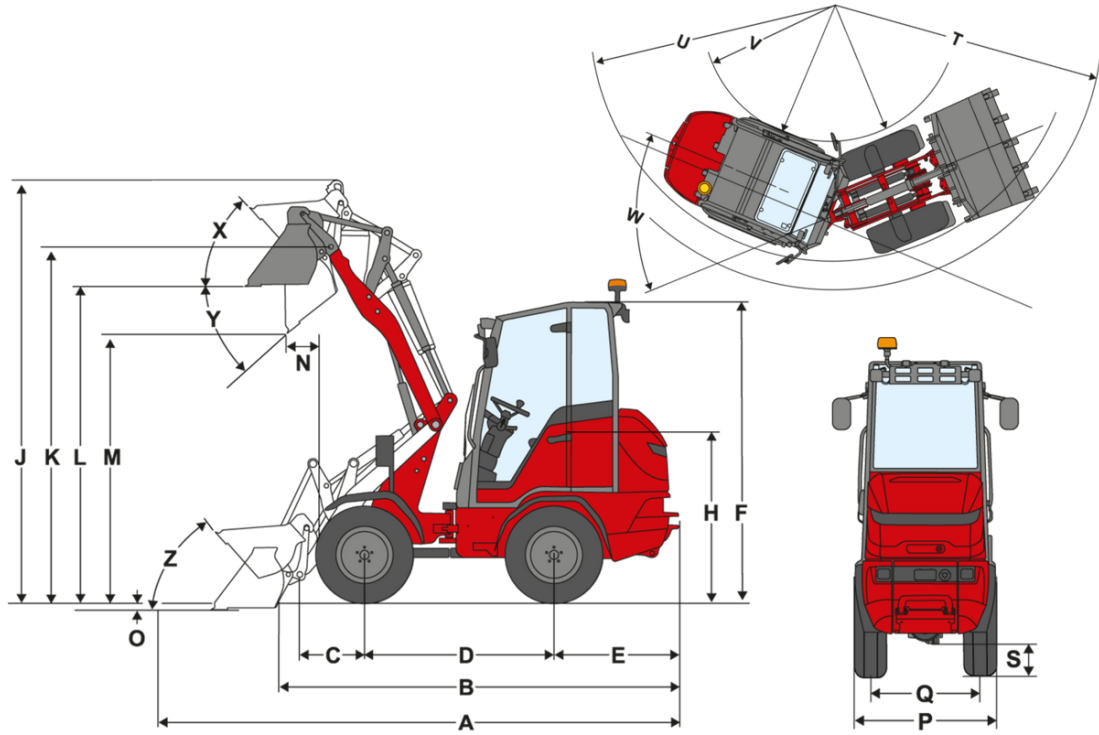

		P-kinematics (Standard)	P-kinematics (long)	PZ-kinematics
A	Total length	4,475 mm	4,820 mm	4,630 mm
B	Total length without bucket	3,635 mm	3,980 mm	3,795 mm
C	Bucket pivot point (to center of axle)	600 mm	905 mm	720 mm
D	Wheel base	1,732 mm	1,732 mm	1,732 mm
E	Rear overhang	1,232 mm	1,232 mm	1,232 mm
F	Height with operator's canopy fixed	2,340 mm	2,340 mm	2,340 mm
	Height with fold-down operator's canopy (eps)	2,395 mm	2,395 mm	2,395 mm
F	Height with fold-down operator's canopy, folded down (eps)	1,910 mm	1,910 mm	1,910 mm
	Height with cab	2,340 mm	2,340 mm	2,340 mm
H	Seat height	1,350 mm	1,350 mm	1,350 mm
J	Total working height	3,680 mm	3,950 mm	3,850 mm
K	Bucket pivot point (max. lift height)	3,024 mm	3,220 mm	3,220 mm
L	Load-over height	2,700 mm	2,905 mm	2,905 mm
M	Dumping height	2,140 mm	2,350 mm	2,400 mm
N	Reach (at M)		490 mm	400 mm
O	Digging depth	60 mm	110 mm	107 mm
P	Total width	1,124 mm	1,124 mm	1,124 mm
Q	Track width	860 mm	860 mm	860 mm
T	Maximum radius	3,000 mm	3,150 mm	3,340 mm
U	Radius on the outer edge	2,730 mm	2,730 mm	3,005 mm
V	Inner radius	1,526 mm	1,526 mm	1,815 mm
W	Articulation angle	45 °	45 °	40 °
X	Rollback angle at max. lift height	42 °	65 °	57 °
Y	Dumping angle	43 °	42 °	37 °
Z	Rollback angle on ground	51 °	56 °	50 °

Standard components

Drive system & Battery

- Battery (lithium-ion), 96 V, battery capacity (gross) 14.1 kWh
- Battery charger On-board 3 kW, plug type 2, charger cable Schuko 230 V / 10 A
- Drive hydraulics motor (ECE R085) 33.1 kW
- Work hydraulics motor (ECE R085) 21.2 kW

Steering system

- Hydraulic articulated pendulum steering, pendulum angle: $\pm 8^\circ$
- Steering cylinder: 1

Operator's cab

- Operator's canopy with ROPS/FOPS-tested restraint system
- Generous provision of space in all operator's cabs
- Ergonomic, generous access
- Adjustable steering column (inclination and height)

Operator's seat

- Fully damped comfort seat with safety belt, weight, back and height adjustment

Lighting

- LED work lights, 2 front, 1 back on the operator's canopy

Drive system & Axles

- Axle: planetary axle PA940
- Drive system: electric drive, energy recuperation when decelerating, travel direction selectable on the joystick, Auto / Eco mode
- Battery: internal battery heater, charge time 20% to 80% SOC 2.9 hr, charge activation switch
- Speed: 15 km/h (optional 20 / 25)
- Speed levels: 2
- Operating brake: multi-disc brake on the front axle effective on the rear axle via the universal joint shaft
- Parking brake: electric parking brake with hill-hold function (the electric motor holds the machine when stopping on a hill)

Tires

- 10.0/75 - 15.3 AS ET40

Loading system

- Lift arm lift height 3040 mm
- Quickhitch facility (Weidemann HV/HT - C) hydraulic
- Kinematics: P
- Lift cylinder: 2
- Tipping cylinder: 1
- Float position for lift and tipping cylinder

Hydraulics

- Mechanically pilot controlled joystick with direction switch
- 3rd Front control circuit via lever with single detent for continuous function

Other

- Cast rear weight

EquipCare (telematics)

- EquipCare 36 months (incl. App & Manager)

Options

Operator's cab

- Fold-down operator's canopy eps ROPS / FOPS tested
- Cabin, 2 one-piece doors incl. heated windshields front and rear
- Cabin, 2 two-piece doors incl. heated windshields front and rear
- Front and rear windshield incl. wipers front and rear
- Faux leather seat; air-sprung (MSG 93)
- Faux leather seat; air-sprung; heated seat (MSG 93)
- Fabric seat (standard for the cabin) (MSG 83)
- Fabric seat; air-sprung (MSG 93)
- Fabric seat; air-sprung; heated seat (MSG 93)
- Roof heating panel
- FM radio-ready (aerial, speaker)
- DAB+ radio-ready (aerial, speaker)
- Complete DAB+ radio
- Sunblind

Lighting

- Lighting according to StVZO road regulations
- LED lighting according to StVZO road regulations
- LED Performance work lights (2000 lm) on roof, 2 front, 2 rear
- Rotating beacon-ready
- LED rotating beacon (yellow), National regulations must be maintained!
- Rotating beacon (yellow) with magnetic base, the national regulations must be maintained!

Approval & Road traffic

- Individual operating permit < 25 km/h
- Number plate mounting front and rear
- Triangular warning sign

Drive system & Axles

- Manual throttle

Axles

- Planetary axle PA940, electric all-wheel drive with lock, transfer case, universal joint shaft, differential lock 100%

Travel speed

- 20 km/h (Speed increase)
- 25 km/h (Speed increase)

Tires

- 11.5/80-15.3 AS ET40 (tread AS, width 1,150 mm (turned 1,340 mm), height 2,364 mm)
- 31x15.50-15 AS ET0 Starco (tread AS, width 1,320 mm, height 2,320 mm)
- 31x15.50-15 AS ET-37 Starco (tread AS, width 1,394 mm, height 2,320 mm)
- 15.0/55-17 AS ET0 (tread AS, width 1,310 mm, height 2,375 mm)
- 15.0/55-17 AS ET-40 (tread AS, width 1,400 mm, height 2,375 mm)
- 425/55 R 17 AS ET-40 Alliance 570 (tread AS, width 1,445 mm, height 2,375 mm)
- 31x15.50-15 EM ET0 (tread EM, width 1,340 mm, height 2,325 mm)
- 31x15.50-15 EM ET-37 (tread EM, width 1,414 mm, height 2,325 mm)
- 12-16.5 EM ET0 (tread EM, width 1,250 mm, height 2,341 mm)
- 425/40 B17 ET0 PR14 Delcora GSP+ (tread EM, width 1,365 mm, height 2,329 mm)
- 31x15.5-15 BKT TracMaster ET 0 (tread RP, width 1,345 mm, height 2,335 mm)
- 33x15.5-15 BKT TracMaster ET-37 (tread RP, width 1,424 mm, height 2,363 mm)
- 10-16.5 Sure Trax ET40 BKT (tread SureTrax, width 1,128 mm (turned 1,300 mm), height 2,323 mm)
- 12-16.5 Sure Trax ET45 BKT (tread SureTrax, width 1,175&# 160; (turned 1,370&# 160;), height 2,358 mm)
- 315/ 55R16 Conti MPT81 ET-30 (tread MPT, width 1,302 mm, height 2,305 mm)

Loading system

- P-Kinematics LS921 lift height (3,200 mm)
- PZ-Kinematics LS937 lift height (3,200 mm)

Quick change plates

- Weidemann HV/HT - C - ECS (hydraulic - easy coupler system)
 - Euro (hydraulic - ISO23206 EURO HV) (incl. two couplings SVK gr. 3)
 - SkidSteer (hydraulic - SAEJ2513 SSL HV)
 - SMS HV (hydraulic)
 - Kramer HV/WL - C (hydraulic)
-
- Lowering brake valve (lift and tipping cylinder pipe breakage protection) incl. float position
 - swing arm dampening
 - bucket status indicator

Hydraulics

- Oil volume adjustment of 3rd control circuit
- Additional hydraulic oil cooler
- Shell PANOLIN S4 HLP Synth 46 (Biohydraulic oil)
- Hydraulic oil - pre-warming

Hydraulics in front

- 3rd control circuit proportional incl. continuous function via switch, pressure release 3rd control circuit front on the charging system, oil volume adjustment (operation: Via scroll wheel in front on the joystick)
- Pressureless return line in front (1 x Flatface size 3, plug) incl. leakage oil line (1 x Flatface size 2, plug)
- Quick coupling Faster 2-fold - machine side
- Quick coupling Faster 2-fold - machine side + attachment side

Hydraulics in rear

- Dual-acting, rear, hydraulic connection via switch valve (two couplings SVK gr. 3), (3rd control circuit front or rear), operation: Via switch (0 - 1) + 3rd control circuit
- Rear depressurized return line (1x SVK gr. 3 plug) incl. overflow oil line (1x flatface gr. 2 plug)

Electrical system

- Lithium-ion battery 18.0 kWh 96V
- Lithium-ion battery 28.0 kWh 96V
- On-board charger up to 6 kW (AC)

Charger cable (on the machine, type 2, multiple selection available)

- Protective contact mains plug (Schuko) 230V/10A (is pre-selected, can be deselected if no charging cable or another charging cable is required)
- CEE, 3-pole 230V/16A (blue)
- CEE, 5-pole 400V/16A (red)
- Type 2 (IEC 62196)
- Adapter set EU (Schuko, CEE 3-pole, CEE 5-pole)

Battery charge level release

- Charge release lockable

front

- Socket front, 13-pole, (2x electrical functions E1/ E2 and lighting), operation: Using 2 keys on the joysticks; 1st function tentative, 2nd function resting
- Socket front, 13-pole, (2x electrical functions E1/ E2 and lighting), operation: Using 2 keys on the joysticks; 1st function tentative, 2nd function resting
- Socket front, 13-pole, (2x electrical functions E1/ E2 and lighting), operation: Using 2 keys on the joysticks; 1st function tentative, 2nd function resting
- Socket front, 13-pole, (2x electrical functions E1/ E2 and lighting), operation: Using 2 keys on the joysticks; 1st function tentative, 2nd function resting

rear

- Socket rear, 3-pole, (2x electrical functions E3/ E4, can be switched over to front socket), operation: Via switch; 1st function tentative, 2nd function resting
- Rear socket 7-pole for lighting rear attachments

Safety options

- Reverse alarm (acoustic)
- Blue safety light, rear
- Immobilizer KAT, operation: via coded ignition key

Custom-made paint finish

- Special painting RAL single color - instead of Weidemann red
- Special painting RAL multicolored

Other

- Floor plate counterweight (100 kg)
- Toolbox, including tool set and hand lever grease press
- Combination box (for combination envelope)
- Combination bag (warning triangle / first aid kit)
- Fully automatic central lubrication unit

Warranty extension

- Economy 24 months (2500 h)
- Economy 36 months (3000 h)
- Economy 48 months (3500 h)
- Economy 60 months (4000 h)
- Premium 24 months (3000 h)
- Premium 36 months (4000 h)
- Premium 48 months (5000 h)
- Premium 60 months (6000 h)

Trailer and recovery equipment

- Trailer hitch ball head K50
- Trailer hitch automatic

Self-propelled work machines with ball hitch

- Trailer hitch automatic